

Secura™ Flooring

Fire & Acoustic Floor System

Installation Manual

March 2025 New Zealand



We value your feedback!

To continue with the development of our products and systems, we value your input. Please send any suggestions, including your name, contact details, and relevant sketches to:

Ask James Hardie™
literaturefeedback@jameshardie.co.nz

Make sure your information is up to date

When specifying or installing Hardie™ fibre cement products, ensure that you have the current manual. Additional installation information, warranties and warnings are available at www.jameshardie.co.nz or Ask James Hardie™ on 0800 808 868.

Contents

1	Background	4
2	Scope	4
3	Product and accessories	5
4	Safe Working Practices	7
4.1	Storage and delivery	9
4.2	Tips for Safe and Easy Handling of Secura™ Flooring	10
5	Installation	11
5.1	Secura™ Flooring – Floating Floor	12
5.2	Ceiling Installation	15
5.3	Floor Penetrations	15
5.4	Ceiling Penetrations	15
5.5	Concrete floor	18

6	Product information	19
6.1	General	19
6.2	Product Mass	19
6.3	Durability	19
6.4	Fire properties	19

	Product Warranty	22
--	-------------------------	-----------

1 Background

James Hardie has developed an acoustic floating floor system using timber joists or concrete floor that is suitable for use as an intertenancy floor. Clause G6 'Airborne and Impact Sound' of the New Zealand Building Code (NZBC), the Sound Transmission Class (STC) and the Impact Insulation Class (IIC) dictate that the acoustic standard for intertenancy floors shall be no less than 55. The James Hardie acoustic floor system has been tested and verified to achieve STC up to 67 and IIC 57. The system has also been tested and verified to have a fire rating up to 60/60/60 FRR. The acoustic performance of the system therefore well exceeds the minimum requirement of Clause G6 of the NZBC. (The acoustic performance of this system has been verified through independent testing at Auckland University and fire performance has been tested/assessed by BRANZ).

Refer to Secura™ Flooring Installation Manual for detailed information regarding its installation and compliance.

2 Scope

Secura™ Flooring fire and acoustic rated system installed in accordance with this manual is suitable for use in dry/wet inter tenancy floor applications in residential or commercial buildings within the scope of the NZS 3604, 'Timber framed Buildings' or buildings covered by specific engineering design (SED). Secura™ Flooring can withstand loadings up to 3kPa (UDL) and 2.7kN concentrated load specified under domestic and residential activities of Table 3.1, (Category A) of the AS/NZS 1170.1 'Structural Design Actions – Permanent, Imposed and Other Actions'.



3 Product and accessories

Table 1

James Hardie product information			
Product	Description	Size (mm)	Code
	<p>A structural flooring product sealed on all six sides for both tiled or heavy grade vinyl covered internal wet and dry area flooring applications.</p> <p>Long edges have a tongue and groove for easy jointing across the joists.</p> <p>Tiled applications: Install sheet with label 'This side down for Tiles' facing down</p> <p>Vinyl/planks/carpet application: Install sheet with label 'This side up for Vinyl' facing up</p>	2400 x 600	405574



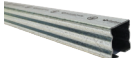





Note: All dimensions provided are approximate only and subject to manufacturing tolerances

Table 2

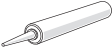
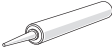
Accessories/tools supplied by James Hardie		
Accessories	Description	Code
	<p>Hardie™ Blade Saw Blade Hardie™ Blade Saw Blade 185mm diameter Used to cut Secura™ Flooring</p>	300660
	Hardie™ Acoustic Floor Channel – 40 x 42 x 1800mm	305922
	Hardie™ Acoustic Cradle	305920
	Hardie™ Flooring Shims	305925

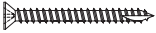
Accessories not supplied by James Hardie

James Hardie recommends the following products for use in conjunction with its flooring products. James Hardie does not supply these products and does not provide a warranty for their use. Please contact the component manufacturer for information on their warranties and further information on their products.

Accessories	Description
	<p>Backing rod PEF backing rod to be used with sealant in control joints.</p>
	<p>Waterproofing membrane Used over the Secura™ Flooring in wet areas. Recommended products from Sika, Ardex, Bostik. Refer to manufacturer for further information.</p>
	<p>Acoustic sealant Sealant used in v joint and around penetrations. Ensure the sealant is compatible with the waterproofing membrane system selected.</p>
	<p>Adhesive Adhesive used over joists prior to installation of Secura™ Flooring. Bostik Seal 'n' Flex 1 Sika Sikaflex 11FC Soudal Soudaseal 215LM</p>
	<p>Level/straight edge For checking straightness of underlying flooring.</p>
	<p>Screws for timber 10g x 40mm wood thread self embedding screws.</p>
	<p>Screws for steel 8-10g x 40-45mm wing tek min. class 3 coating.</p>
	<p>Nails for timber 50 x 2.87mm stainless steel ring RounDrive nail 50 x 2.87mm Dekfast HD galvanised RounDrive nail</p>
	<p>Paslode® Impulse FrameMaster or ECKO Hammahand®</p>
	<p>Allproof Acoustic Pipe Sleeve or similar</p>
	<p>Fire collar Allproof drop in fire collar</p>

4 Safe Working Practices

WARNING - DO NOT BREATHE DUST AND CUT ONLY IN WELL VENTILATED AREA

Hardie™ fibre cement products contain sand, a source of respirable crystalline silica. May cause cancer if dust from product is inhaled. Causes damage to lungs and respiratory system through prolonged or repeated inhalation of dust from product.

Intact fibre cement products are not expected to result in any adverse toxic effects. The hazard associated with fibre cement arises from the respirable crystalline silica present in dust generated by activities such as cutting, rebating, drilling, routing, sawing, crushing, or otherwise abrading fibre cement, and when cleaning up, disposing of or moving dust.

When doing any of these activities in a manner that generates dust, follow James Hardie's instructions and best practices to reduce or limit the release of dust.

If using a dust mask or respirator, use an AS/NZS 1716 P1 filter and refer to Australian/New Zealand Standard 1715:2009 Selection, Use and Maintenance of Respiratory Protective Equipment for more extensive guidance and more options for selecting respirators for workplaces. For further information, refer to our installation instructions and Safety Data Sheets available at www.jameshardie.co.nz.

FAILURE TO ADHERE TO OUR WARNINGS, SAFETY DATA SHEETS, AND INSTALLATION INSTRUCTIONS MAY LEAD TO SERIOUS PERSONAL INJURY OR DEATH.

Crystalline Silica is

- Commonly known as sand or quartz
- Found in many building products e.g. concrete, bricks, grout, wallboard, ceramic tiles, and all fibre cement materials

Why is Crystalline Silica a health hazard?

- Silica can be breathed deep into the lungs when present in the air as a very fine (respirable) dust
- Exposure to silica dust without taking the appropriate safety measures to minimise the amount being breathed in, can lead to a potentially fatal lung disease – silicosis – and has also been linked with other diseases including cancer. Some studies suggest that smoking may increase these risks
- The most hazardous dust is the dust you cannot see!

When is Crystalline Silica a health hazard?

- It's dangerous to health if safety protocols to control dust are not followed when cutting, drilling or rebating a product containing crystalline silica
- Products containing silica are harmless if intact (e.g. an un-cut sheet of wall board)

Avoid breathing in crystalline silica dust

Safe working practices

- ✗ NEVER use a power saw indoors or in a poorly ventilated area
- ✗ NEVER dry sweep
- ✓ ALWAYS use M Class or higher vacuum or damp down dust before sweeping up
- ✗ NEVER use grinders
- ✓ ALWAYS use a dust reducing circular saw equipped with a sawblade specifically designed to minimise dust creation when cutting fibre cement – preferably a sawblade that carries the Hardie™ Blade name or one with at least equivalent performance – connected to an M Class or higher vacuum
- ✓ Before cutting warn others in the area to avoid dust
- ✓ ALWAYS follow tool manufacturers' safety recommendations
- ✓ ALWAYS expose only the minimum required depth of blade for the thickness of fibre cement to be cut
- ✓ ALWAYS wear a properly-fitted, approved dust mask or respirator P1 or higher in accordance with applicable government regulations and manufacturer instructions
- ✓ Consider rotating personnel across cutting tasks to further limit respirable silica exposures.

Use one of the following for cutting:

Best

- Hardie™ Knife
- Hand guillotine
- Fibreshear

Better

Dust reducing circular saw equipped with Hardie™ Blade Saw Blade and connected to a M Class or higher vacuum.

When cutting outdoors

- ✓ Make sure you work in a well ventilated area
- ✓ Position cutting station so wind will blow dust away from yourself and others in the working area
- ✓ Cut products with either a Hardie™ Knife or fibre cement shears or, when not feasible, a Hardie™ Blade Saw Blade (or equivalent) and a dust reducing circular saw connected to a M Class or higher vacuum
- ✓ When sawing, sanding, rebating, drilling or machining fibre cement products, always:
 - Wear your P1 or higher mask (correctly fitted in accordance with manufacturers' instructions), ask others to do the same.
 - Keep persons on site at least 2 metres and as far as practicable away from the cutting station while the saw is in operation
 - If you are not clean shaven, then use a powered air respirator with a loose-fitting head top
 - Wear safety glasses
 - Wear hearing protection
 - When others are close by, ask them to do the same
- ✓ Make sure you clean up BUT never dry sweep. Always hose down with water/wet wipe or use an M Class or higher vacuum

When cutting indoors

- ✗ Never cut using a circular saw indoors
- ✓ Position cutting station in a well ventilated area
- ✓ Cut ONLY using a Hardie™ Knife, hand guillotine or fibreshears (manual, electric or pneumatic)
- ✓ Make sure you clean up BUT never dry sweep. Always hose down with water/wet wipe or use an M Class or higher vacuum

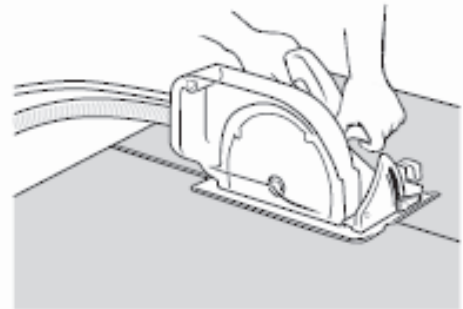

Working instructions

Hardie™ Blade Saw Blade

The Hardie™ Blade Saw Blade used with a dust-reducing saw is ideal for fast, clean cutting of Hardie™ fibre cement products. A dust-reducing saw uses a dust collector connected to a M Class or higher vacuum. When sawing, clamp a straight edge to the sheet as a guide and run the saw base plate along the straight edge when making the cut.

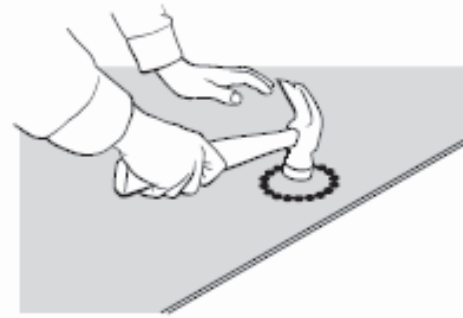

Hole forming

For smooth clean cut circular holes:

- Mark the centre of the hole on the sheet
- Pre-drill a 'pilot' hole
- Using the pilot hole as a guide, cut the hole to the appropriate diameter with a hole saw fitted to a heavy duty electric drill

For irregular holes:

- Small rectangular or circular holes can be cut by drilling a series of small holes around the perimeter of the hole then tapping out the waste piece from the sheet face
- Tap carefully to avoid damage to sheets, ensuring that the sheet edges are properly supported

4.1 Storage and delivery

Keeping products and people safe

Off loading

- ✓ Hardie™ fibre cement products should be off-loaded carefully by hand or by forklift
- ✓ Hardie™ fibre cement products should not be rolled or dumped off a truck during the delivery to the jobsite

Storage

Hardie™ fibre cement products should be stored:

- ✓ In their original packaging
- ✓ Under cover where possible or otherwise protected with a waterproof covering to keep products dry

- ✓ Off the ground – either on a pallet or adequately supported on timber or other spacers
- ✓ Flat so as to minimise bending

Hardie™ fibre cement products must not be stored:

- ✗ Directly on the ground
- ✗ In the open air exposed to the elements

James Hardie is not responsible for damage due to improper storage and handling.

4.2 Tips for Safe and Easy Handling of Secura™ Flooring

- ✓ Carry with two people
- ✓ Hold near each end and on edge
- ✓ Exercise care when handling sheet products to avoid damaging the edges/corners

Figure 1: First sheet installation

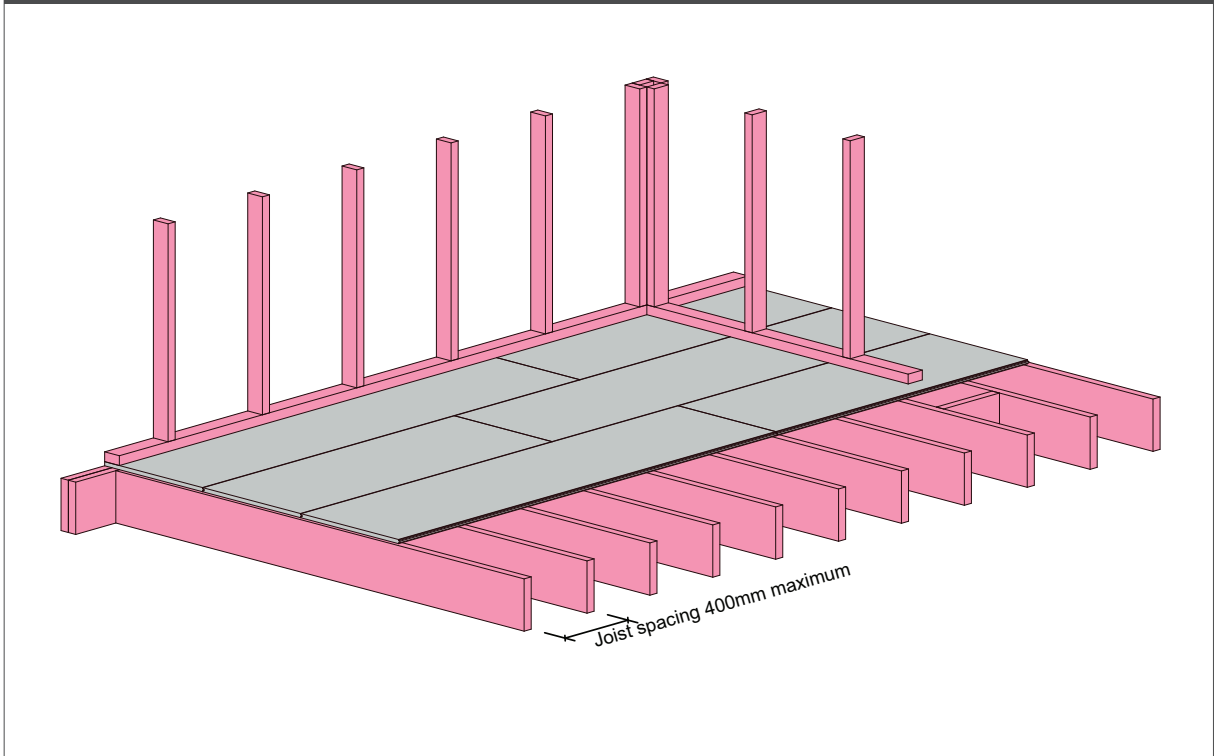

5 Installation

James Hardie fire and acoustic floor system is built using the standard floor construction methodologies used in light weight timber frame building construction. The floor system uses two layers of Secura™ Flooring, the first layer is fixed to the timber floor joists and the second layer fixed into the steel channels over the rubber cradle creating a floating floor.

Secura™ Flooring over joists:

Refer to Secura™ Flooring Installation Manual for detailed information regarding its installation and compliance.

- Solid timber floor joists sizes can be selected as per the NZS 3604 design tables
- Alternatively hySpan/hyJoist floor joists can also be used for the construction of this floor system
- Joist spacing must be at 400mm maximum centres
- Secura™ Flooring must be laid across the joists
- A bead of adhesive e.g. Sikaflex 11FC, Bostik Seal n Flex-1 or Soudaseal 215LM be applied over the joists before fixing the sheets
- The long sheet edges are manufactured with a tongue and groove edge. The long sheet edges are to be butted to form a tight tongue and groove joint. Tap the sheets tight using a wooden block along the edge to avoid damaging the edge

- Run Secura™ Flooring across the floor joists and fix flooring sheets using annular grooved gun nails 50 x 2.87mm, or they can also be screw fixed using a 50mm x 10g timber thread self-embedding screws at 200mm centres maximum to floor joists

After the floor installation has been completed, the construction above the floor should be carried out as per the normal practice. Once the internal walls have been completed with internal lining, the installation of the second layer of Secura™ Flooring can commence.

5.1 Secura™ Flooring – Floating Floor

- Position the Hardie™ Acoustic Cradles on the floor starting from one edge of the room. The cradles allow the placement of Hardie™ Acoustic Floor Channel over it. Acoustic cradles must be placed at 450mm centres maximum along the length of Hardie™ Acoustic Floor Channel. It calculates to @ 7 cradles/m² of the floor area. Refer to Figure 3
- Hardie™ Acoustic Cradles are placed along the perimeter of room with a 10mm gap from the internal lining. Refer to Figures 3 and 6
- Place the Hardie™ Acoustic Channel into the Acoustic Cradle. The maximum spacing between the Hardie™ Acoustic Floor Channel must not exceed 400mm centres. The Hardie™ Acoustic Channels can run in either direction of the room i.e. independent of the floor joist or Secura™ Flooring layout below
- Acoustic insulation 75mm thick (density 9.6kg/m³ minimum) tightly fitted in between the Acoustic Channels to create a damping effect
- Lay Secura™ Flooring across the Hardie™ Acoustic Channel and fix to the Acoustic Channels using a 50mm x10g self-tapping steel screw at 200mm centres along the channel. The long sheet edges are to be butted together to form a tight tongue and groove joint. Refer to Figure 5
- Allow a 5-8mm gap between the Secura™ Flooring and wall lining around the perimeter. The gap is filled up with a PEF rod and sealed with an acoustic sealant. Refer to Figure 6

Figure 2: Fastener layout

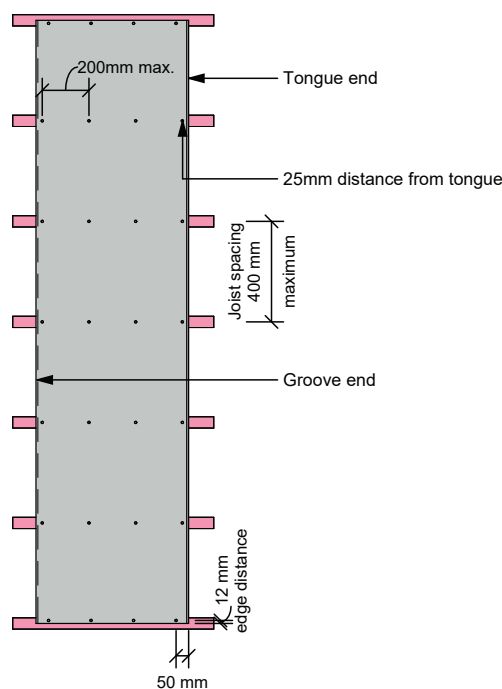

Figure 3: Batten and cradle layout

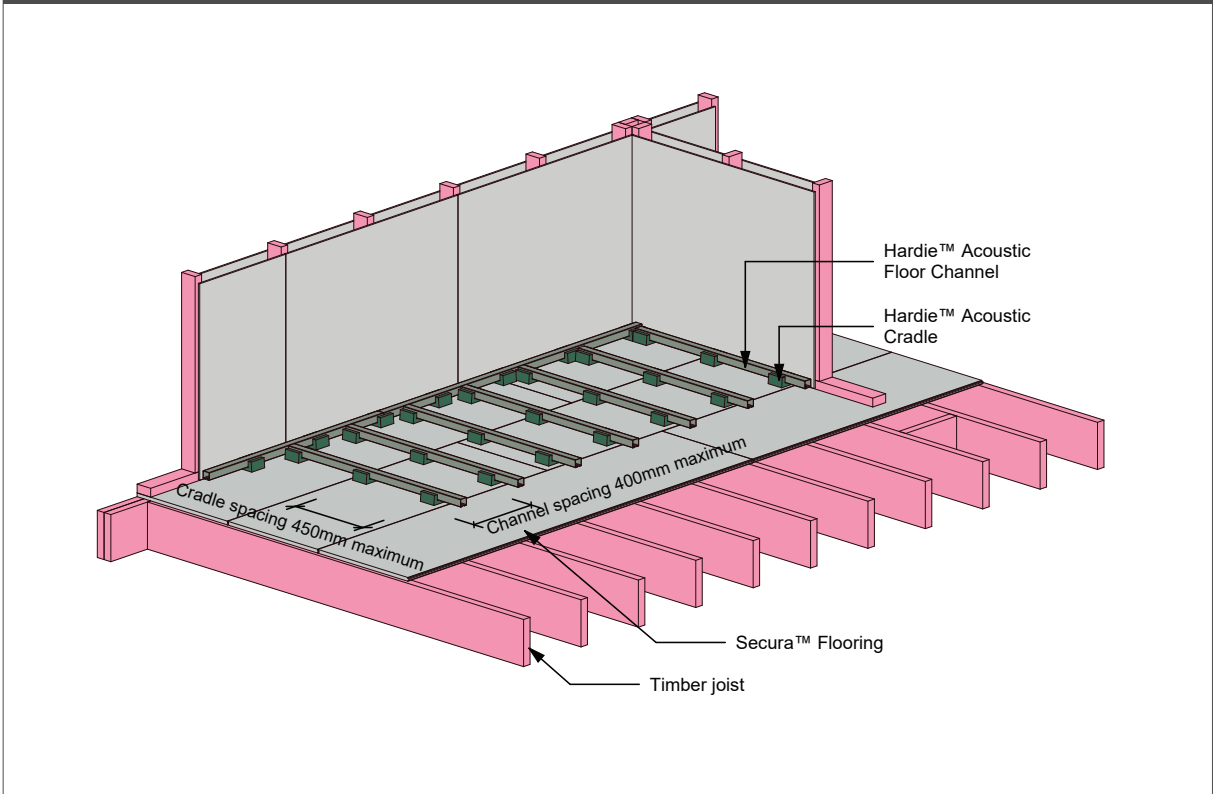

Figure 4: Insulation installation

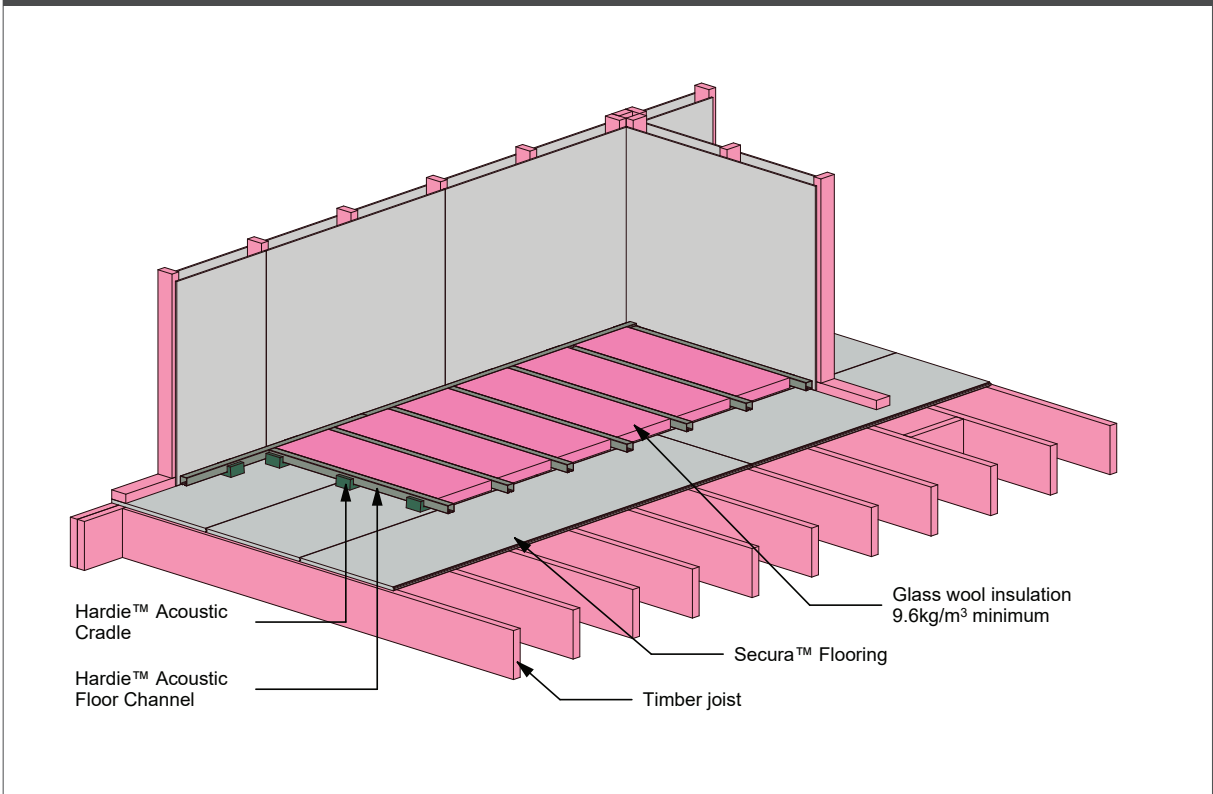

Figure 5: Second sheet installation

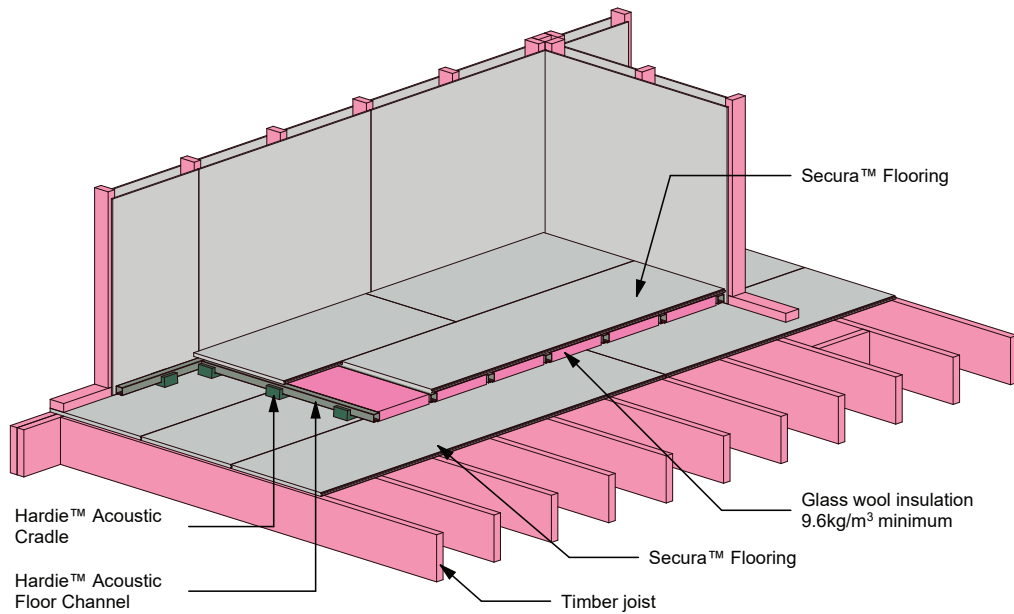
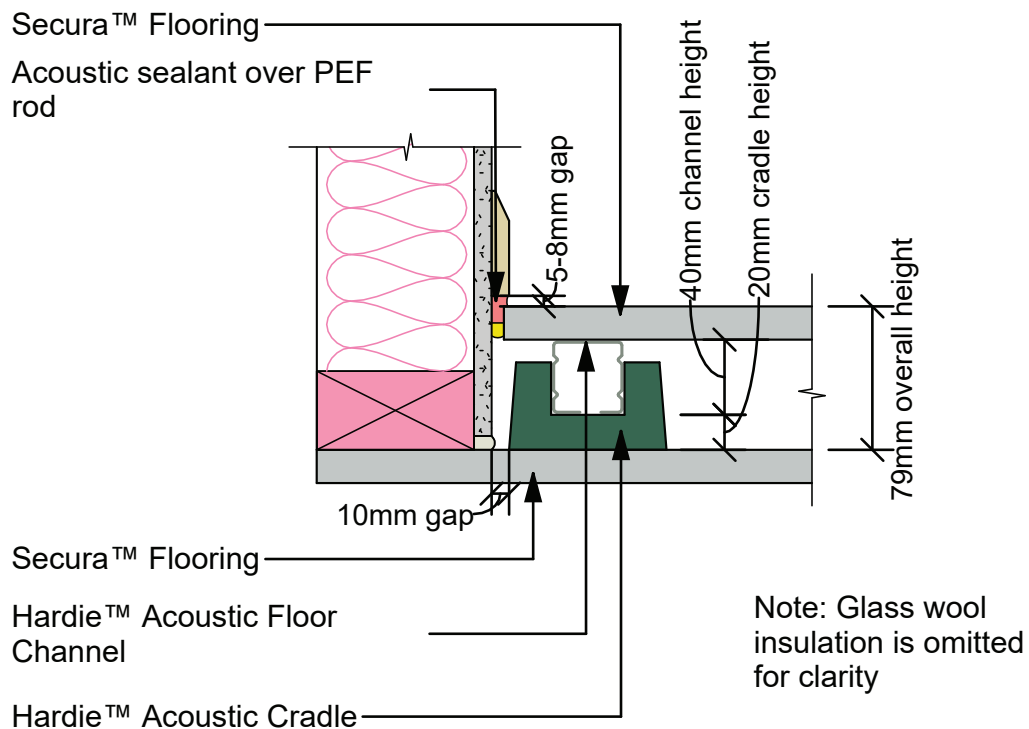

Figure 6: Floor to wall junction



5.2 Ceiling Installation

The installation of GIB® Rondo® channels and 2 x 13mm GIB Fyrelite® is as per the information published by Winstone Wallboards Limited. Refer to 'GIB® Fire Rated Systems' technical specification for information regarding their installation.

5.3 Floor Penetrations

For pipe penetrations through the floor cut 10mm oversize hole through the Secura™ Flooring. Fit the pipe through the penetration and then seal around with an acoustic sealant. Refer Figures 7 and 8.

5.4 Ceiling Penetrations

Penetrations through a fire rated system, if they are not correctly specified, installed and tested, can allow spread of fire and smoke from one fire cell to another.

As a general guidance Gartner Superlux Limited have tested a few light fittings in conjunction with GIB Fyrelite® for use in fire rated ceiling application. Based on this testing they publish information for the installation of their light fittings as to what is the maximum surface area allowed and minimum distance to be maintained between the light fittings etc. Refer to Gartner Superlux for further information.

It is suggested that the information published in 'GIB® Fire Rated Systems' specification and Gartner Superlux Limited is referred to before specifying any penetrations through a fire rated ceiling. Also check with the proprietary seals manufacturer/supplier for the installation details of their products and its test data.

Figure 7: Services running parallel floor joists

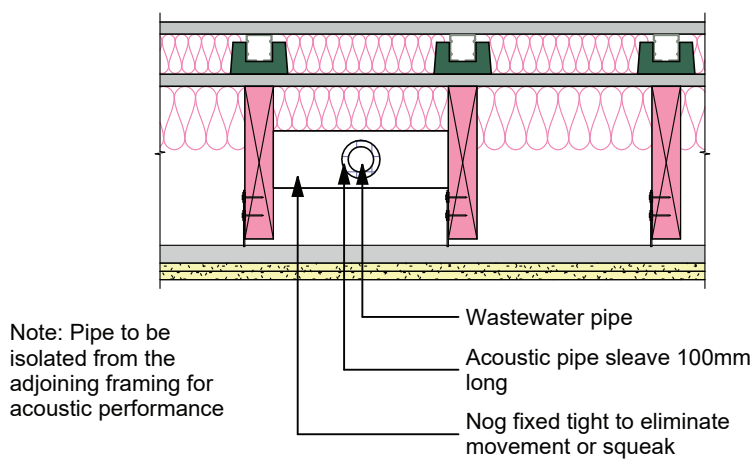
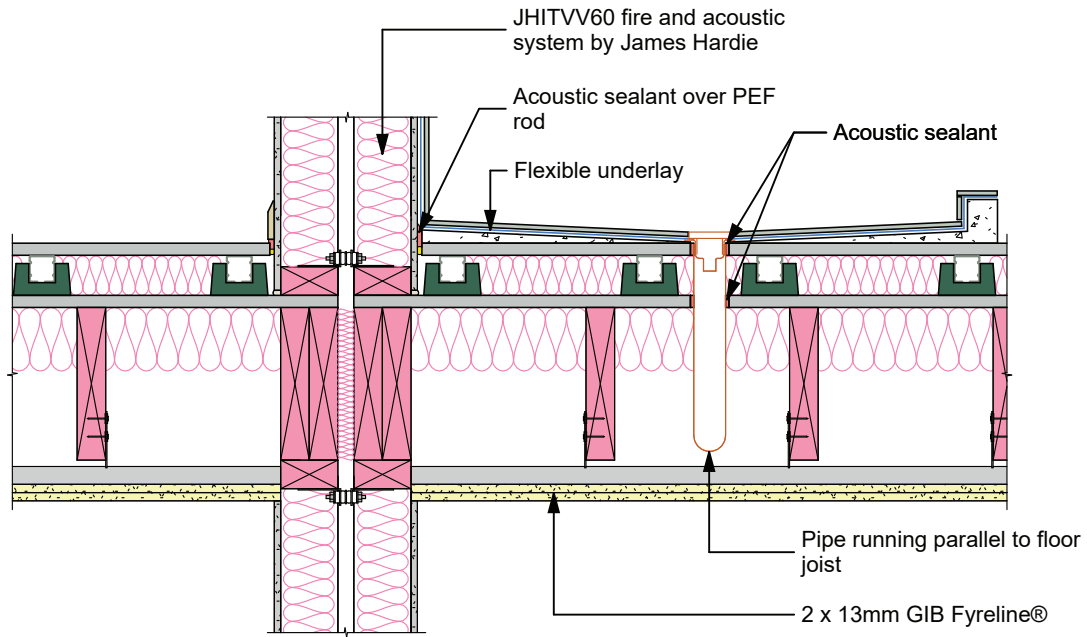
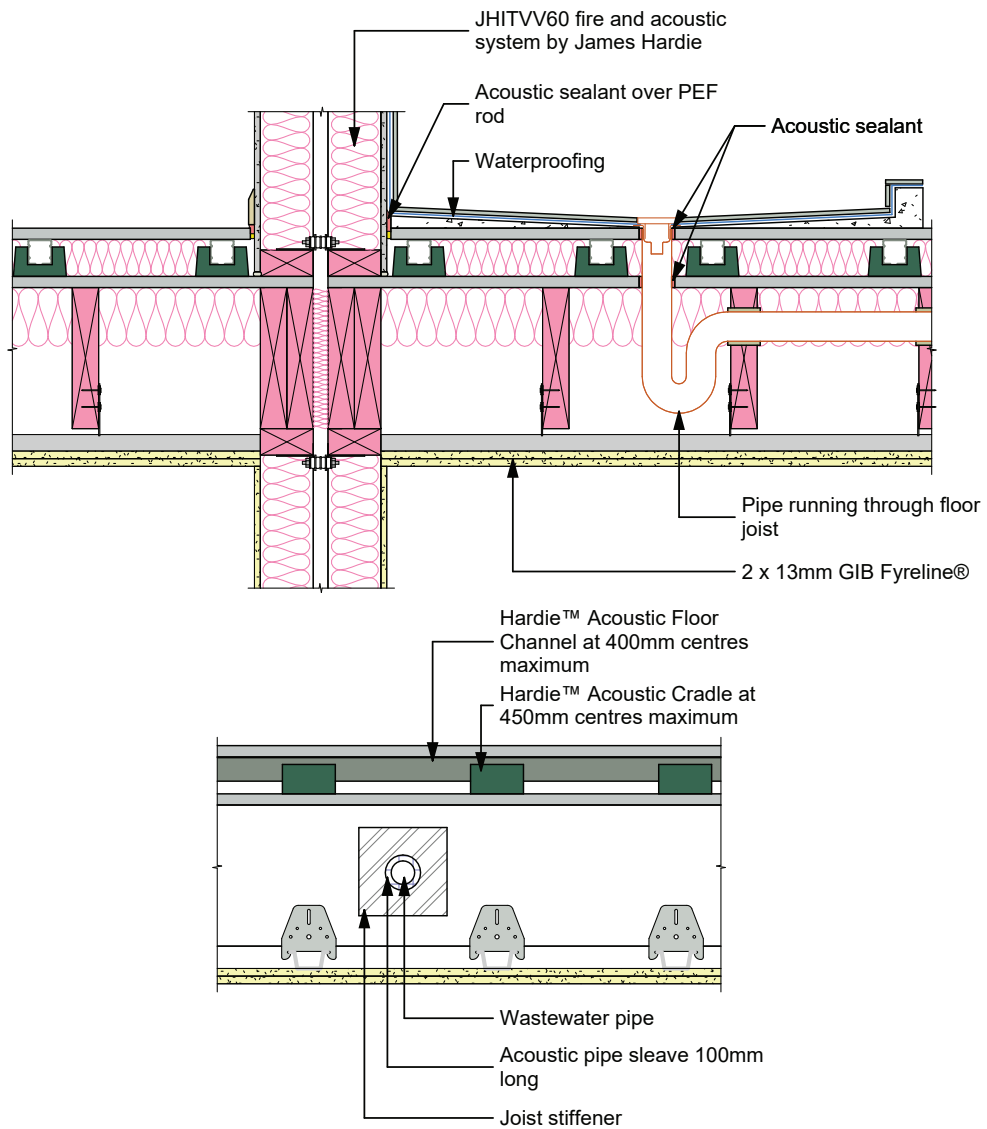

Figure 8: Services running through floor joists



5.5 Concrete floor

When using the concrete floor construction methodology for an intertenancy floor application, ensure the design of concrete floor is suitable to achieve the required fire rating.

To achieve the required Impact Insulation Class (IIC) performance, Secura™ Flooring can be fixed as a floating floor application over the concrete floor. Refer to Figure 9 for details.

James Hardie has assessed the acoustic performance of various types of concrete floor solutions in conjunction with Secura™ Flooring as a floating floor.

The acoustic performance of a typical tray deck concrete floor construction as per Figure 9 is STC 70 and IIC 58.

Contact James Hardie for any further information on acoustic performance of floors.

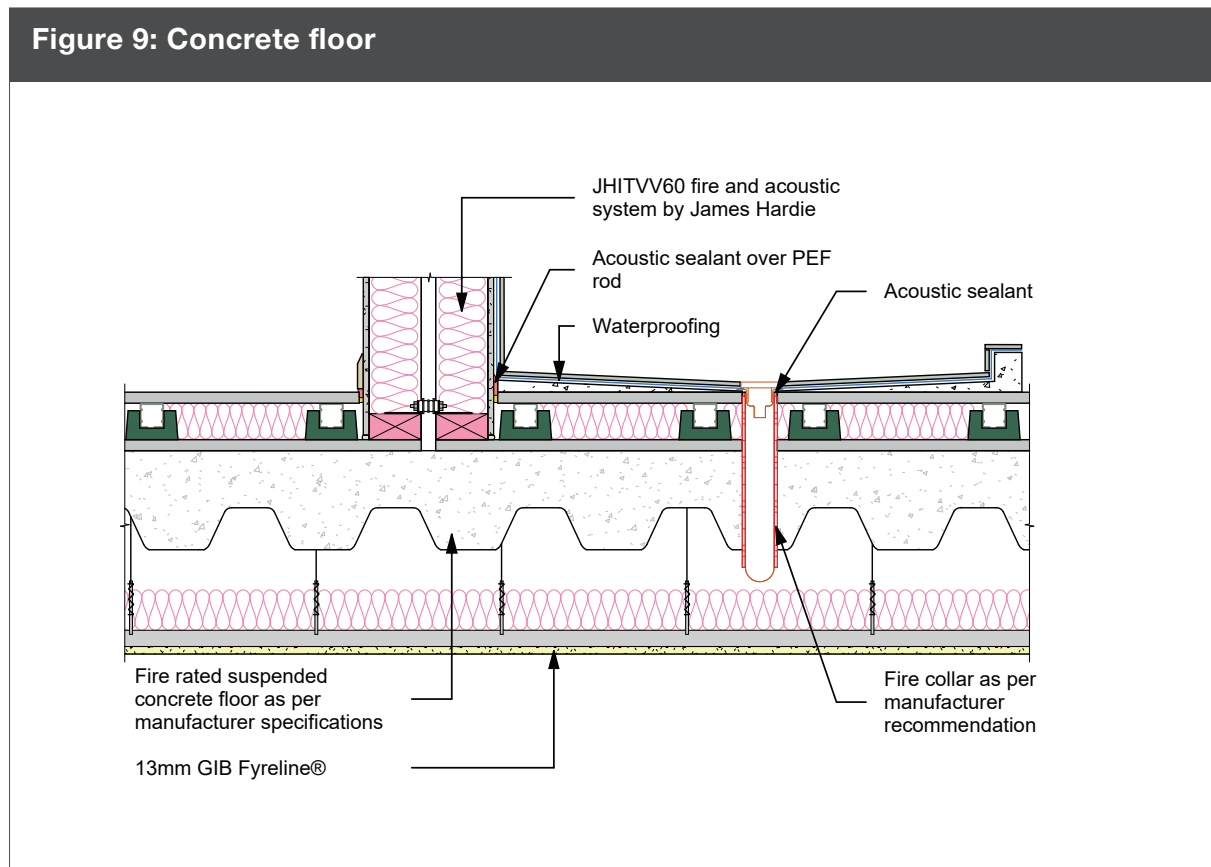

6 Product information

6.1 General

Secura™ Flooring is an advanced lightweight cement composite building product. The basic composition is Portland cement, ground sand, cellulose fibre, water and proprietary additives.

Secura™ Flooring is manufactured to AS/NZS 2908.2 'Cellulose-Cement Products Part 2: Flat Sheets' (ISO 8336 'Fibre Cement Flat Sheets').

Secura™ Flooring is a classified Type B, Category 3 in accordance with AS/NZS 2908.2 'Cellulose-Cement Products'.

6.2 Product Mass

Based on equilibrium moisture content the approximate mass of:

Secura™ Flooring is 24.5kg/m².

6.3 Durability

Resistance to moisture/rotting

Secura™ Flooring has demonstrated resistance to permanent moisture induced deterioration (rotting) by having passed the following tests in accordance with AS/NZS 2908.2:

Heat rain (Clause 6.5)

Water permeability (Clause 8.2.2)

Warm water (Clause 8.2.4)

Soak dry (Clause 8.2.5)

6.4 Fire properties

Secura™ Flooring is classified as a non-combustible material. Secura™ Flooring is suitable for use in intertenancy fire rated floor applications and has been tested to meet performance requirements.

Product Warranty

NEW ZEALAND | Effective March 2025

This warranty is given by James Hardie New Zealand Limited (“James Hardie”, “we”, “its” and “us”).

In this warranty:

- **“Consumer”** has the meaning given to it in the Consumer Guarantees Act; ;
- **“Product”** refers to the item listed below:

Secura™ Flooring

- **“Technical Literature”** means the product specific installation guide published by James Hardie at the time of installation of the product (copies of the current installation instructions are available at jameshardie.co.nz or by calling Ask James Hardie™ on 0800 808 868); and
- **“Warranty Period”** means twenty five (25) years.

Warranty

1. Subject to the conditions and limitations set out below, we warrant that for the Warranty Period from the date of purchase, the Product will be free from defects due to defective factory workmanship or materials.
2. James Hardie further warrants that for a period of 15 years from the date of purchase of the Product that any associated accessories supplied by us will be free from defects due to defective factory workmanship or materials.
3. James Hardie warrants that at the time of manufacture the Product will comply with AS/NZS 2908.2:2000 Cellulose-cement products - Flat sheet.
4. This warranty is not transferable and is only provided to and may only be relied upon by:
 - (a) the first purchaser of the Product or accessory from James Hardie; and
 - (b) the last purchaser of the Product or accessory prior to installation.
5. If a breach of this warranty occurs, we will (at our option) either: supply replacement Product or accessory; rectify the affected Product or accessory; or pay for the reasonable and substantiated cost of the replacement or rectification of the affected Product or accessory.

Warranty Conditions

6. You may only claim under this warranty if:
 - (a) the Product was installed and maintained strictly in accordance with the Technical Literature including the components or products specified or recommended in the Technical Literature; and
 - (b) other products applied to or used in conjunction with the Product are applied or installed and maintained strictly in accordance with the relevant manufacturer’s instructions and good trade practice; and
 - (c) the Product is used in an application designed and constructed in strict compliance with all relevant provisions of the New Zealand Building Code (**“NZBC”**), applicable laws, regulations and standards; and
 - (d) we are given reasonable opportunity to inspect the Product **before** any attempt is made to repair or remove the Product once it has been installed; and
 - (e) the requirements for bringing a claim under the warranty as set out in clause 8 are complied with.

7. Subject to clauses 10 and 11:

- (a) to the fullest extent permitted by law, we exclude all:
 - (i) other warranties, conditions, liabilities and obligations which may otherwise apply in respect of the purchase or use of the Product and/or its Technical Literature, other than those specified in this warranty; and
 - (ii) liability for any loss or damage (whether direct or indirect) including property damage or personal injury, consequential loss, economic loss or loss of profits, the purchase or use of the Product and/or its Technical Literature whether arising in contract, tort (including negligence), statute or equity.
- (b) if or to the extent that it is not permitted by law to so limit our liability as set out in clause 7(a), then to the fullest extent permitted by law, we limit our liability at our option to:
 - (i) the replacement of the Product or accessory or the supply of equivalent Product or accessory;
 - (ii) the repair of the Product or accessory;
 - (iii) the payment of the cost of replacing the Product or accessory, or of acquiring equivalent Product or accessory; or
 - (iv) the payment of the reasonable and substantiated cost of having the Product or accessory repaired;
- (c) this warranty does not cover defects which are not due to defective factory workmanship or materials, including but not limited to damage or defects caused by or arising from or attributable to:
 - (i) use of the Product in applications not recommended by us or in accordance with the Technical Literature;
 - (ii) the Product being subjected to abnormal treatment including impact, abrasion or mechanical action;
 - (iii) surface marking, scratches or stains arising during or after the installation of the Product;
 - (iv) poor workmanship or installation, poor design or detailing, settlement or structural movement and/or movement of materials to which the Product is attached;
 - (v) incorrect design of the structure;
 - (vi) acts of God including but not limited to earthquakes, fire, cyclones, floods or other severe weather conditions or unusual climatic conditions;
 - (vii) efflorescence, normal wear and tear, growth of mould, mildew, fungi, bacteria, or any organism on any Product surfaces or Product (whether on the exposed or unexposed surfaces);

- (viii) contact with chemicals such as solvents, detergents and pollutants, or exposure to a harsh chemical environment or an excessively salty environment;
- (ix) use of adhesive tapes, sealants or mastics on the Product, or recoating of the surface of the Product outside of the recommended maintenance guidelines in the Technical Literature; or
- (x) failure of third party coating systems, including but not limited to sealers and paints; and
- (xi) **this warranty does not cover** any variation in the look of the Product including but not limited to: any variation in colour or surface pattern; any variation between different batches of the Product; or any variation against any sample material provided. The architect/builder/installer must ensure **prior to specification** that variation in look between items of Product is acceptable and ensure that each item of Product meets all aesthetic requirements **prior to installation**. Subject to the terms of this warranty, after installation of the Product, **we are not liable** for claims arising from aesthetic variations or defects if such variations or defects were, or would upon reasonable inspection have been, **apparent prior to installation**.

Making a Claim Under Warranty

If you are the property owner and did not purchase the product yourself, and you believe you have any issue with James Hardie product installed at your home, in the first instance you should contact the builder who purchased and installed the product. If you purchased the product yourself, you can make a claim under this warranty as detailed below.

8. In order to make a claim under this warranty, you must provide the following information in writing to us using the contact details below within 30 days after the alleged defect would have become reasonably apparent or, if the defect was reasonably apparent prior to installation, then the claim must be made prior to installation:
 - (a) proof of purchase;
 - (b) description of the defect and the issue;
 - (c) photographs of the defect; and
 - (d) your contact details.
9. Subject to New Zealand Consumer Law, you must bear any expenses you incur as a result of claiming under this warranty, except where you are entitled to recover such expenses under the New Zealand Consumer Law, in which case we will bear or otherwise reasonably compensate you for such expenses. All claims for such expenses are to be notified to us in writing within 21 days from the later of: when you make a claim under this warranty; or when we notify you that we, acting reasonably, accept responsibility for these expenses.

New Zealand Consumer Law

10. If you acquire the Product or accessories manufactured or supplied by us as a Consumer, that Product or accessories may come with guarantees that cannot be excluded under the Consumer Guarantees Act. If so, and we are a supplier, you are entitled to a replacement or refund for a failure of a substantial character or a failure that cannot be remedied, and compensation for any other reasonably foreseeable loss or damage. You are also entitled to have the goods repaired or replaced if the goods fail to be of acceptable quality or fail to meet some other guarantee and can be remedied and the failure is not of a substantial character. Where we or a related entity are the manufacturer, then you will have the rights set out in the Consumer Guarantees Act if the goods do not comply with this warranty or the consumer guarantees under the Consumer Guarantees Act.
11. Other than as lawfully excluded or limited by the other terms of this warranty, any rights a Consumer may have under this warranty are in addition to other rights and remedies of a Consumer under a law in relation to the goods to which this warranty relates. Nothing in this warranty shall exclude or modify any legal rights a purchaser and/or Consumer may have under the Consumer Guarantees Act, Fair Trading Act or otherwise which cannot be excluded or modified at law.

Disclaimer

The recommendations in James Hardie's literature are based on good building practice but are not an exhaustive statement of all relevant information. Further, as the successful performance of the relevant system depends on numerous factors outside the control of James Hardie (e.g. quality of workmanship and design) James Hardie shall not be liable for the recommendations made in that Technical Literature and the performance of the relevant system, including its suitability for any purpose or ability to satisfy the relevant provisions of the NZBC, laws, regulations and standards. It is the responsibility of the building designer to ensure that the details and recommendations provided in the relevant James Hardie Technical Literature are suitable for the intended project and that specific design is conducted where appropriate.

Our Contact Details

James Hardie New Zealand Limited

Address: 1 O'Rorke Road, Penrose, Auckland, 1061

Postal address: PO Box 12070, Penrose, Auckland 1642

Telephone: "Ask James Hardie™" on 0800 808 868

Website: www.jameshardie.co.nz

Email: info@jameshardie.co.nz

