

Axon™ Panel Direct Fixed

Technical Specification

March 2024 New Zealand





We value your feedback!

To continue with the development of our products and systems, we value your input. Please send any suggestions, including your name, contact details, and relevant sketches to:

Ask James Hardie™
literaturefeedback@jameshardie.co.nz

Make sure your information is up to date

When specifying or installing Hardie™ fibre cement products, ensure that you have the current manual. Additional installation information, warranties and warnings are available at www.jameshardie.co.nz or **Ask James Hardie™** on 0800 808 868.

**THIS TECHNICAL
SPECIFICATION
IS FOR
AXON™ PANEL
DIRECT FIXED**

Contents

1	Product Information	4	6	Installation	15
1.1	Product Sizes and Accessories	4	6.1	General	15
1.2	Components and Accessories	6	6.2	Timber Framing	15
1.3	Manufacturing and Classification	8	6.3	Flexible Underlay or HomeRAB™ Pre-Cladding	15
2	Application	8	6.4	Flashing	16
2.1	Application	8	6.5	Junctions and Penetrations	16
2.2	Scope	8	6.6	Control of External Fire Spread	16
2.3	Details	9	6.7	Resistance to Moisture/Rotting	16
3	Design	9	6.8	Alpine Regions	16
3.1	Compliance	9	6.9	Fastener Durability	16
4	Design	10	6.10	Fastener — Type, Size and Layout	17
4.1	Responsibility	10	6.11	Panel Layout	19
4.2	Clearances	10	6.12	Vertical Joint	19
4.3	Structure	10	6.13	Horizontal Joint	19
4.4	Moisture Management	11	6.14	External Corner	19
4.5	Energy Efficiency	11	6.15	Internal Corner	19
4.6	Bracing	11	6.16	Flashing Material Durability	19
4.9	Fire Rated Walls	11	6.17	Board and Batten Look	19
4.11	Steel Framing	11	7	Finishing	20
4.12	Construction Methods	11	7.1	Preparation	20
4.13	Tolerances	11	7.2	Coating	20
5	Safe Working Practices	12	7.3	Flexible Sealant	20
5.1	Storage and Delivery	14	8	Care and Maintenance	21
5.2	Tips for safe and easy handling of Axon™ Panel	14	9	Product information	21
			9.1	Manufacturing and Classification	21
			10	Details	22
			Product Warranty	51	

1 Product Information

Grooved



Axon™ Panel 133mm Grooved

The grooves on the face panel are nominal 10mm wide x 2.25mm deep and spaced at 133mm centres.



Axon™ Panel 133mm Grooved Grained

The grooves on the face panel are nominal 10mm wide x 2.25mm deep and spaced at 133mm centres. Between the grooves is a look of traditional wood-grain texture.



Axon™ Panel 400mm Grooved

The grooves on the face panel are nominal 10mm wide x 2.25mm deep and spaced at 400mm centres.

Textured



Axon™ Panel Smooth

Formerly known as EasyLap™ Panel

Provides a durable, shiplap vertical joint panel appearance for residential/commercial building façades. The panel is finished with either a site applied roll on textured acrylic paint to create a rendered look with subtle vertical joint or a full mesh texture coating system.



Axon™ Brushed Concrete must be installed with the Hardie™ CLD™ Structural Cavity Batten. Refer to the Axon™ Panel Hardie™ CLD™ technical specification when installing the Axon™ Panel Brushed Concrete texture.

1.1 Product Sizes and Accessories

Table 1

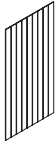
Note: Axon™ Panel cladding is defined as a Light Weight Wall Cladding (not exceeding 30kg/m²) as per the NZS 3604.

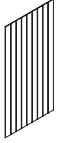
Axon™ Panel Grooved					
Product	Description	Thickness (mm)	Size		Product Code
			Length (mm)	Width (mm)	
	Axon™ Panel 133mm Grooved Is a shiplap jointed panel to hide the panel joints. The panel is face primed. The panel has grooves at 133mm centres. The panel must be installed vertically. Nom. Panel Mass: 12.1kg/m ²	9	2450	1200	403780
			2750	1200	403781
			3000	1200	403782
			3600	1200	404979

Axon™ Panel Grooved					
Product	Description	Thickness (mm)	Size		Product Code
	<p>Axon™ Panel 133mm Grooved Grained</p> <p>Is a shiplap jointed panel to hide the panel joints. The panel is face primed. The panel has grooves at 133mm centres. The panel must be installed vertically.</p> <p>Nom. Panel Mass: 12.1kg/m²</p>	9	3000	1200	404512
	<p>Axon™ Panel 400mm Grooved</p> <p>Is a shiplap jointed panel to hide the panel joints. The panel is face primed. The panel has grooves at 400mm centres. The panel must be installed vertically.</p> <p>Nom. Panel Mass: 12.1kg/m²</p>	9	2450	1200	404414
			2750	1200	404415
			3000	1200	404416

Axon Panel Textured					
Product	Description	Thickness (mm)	Size		Product Code
	<p>Axon™ Panel Smooth</p> <p><i>Formerly known as EasyLap™ Panel</i></p> <p>A shiplap edge panel for subtle vertical joints</p> <p>Nom. Panel Mass: 12.1kg/m²</p>	9	Length (mm)	Width (mm)	Product Code
			2450	1200	404764
			3000	1200	404763

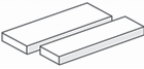
Hardie™ Axent™ Trim information					
Product	Description	Thickness (mm)	Size		Product Code
	For box corners and facings	19	Length (mm)	Width (mm)	Product Code
			3000	45	405260
			3000	70	405257
			3000	89	405258

Note: All dimensions and masses provided are approximate only and are subject to manufacturing tolerances.

1.2 Components and Accessories

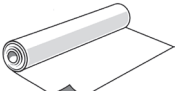
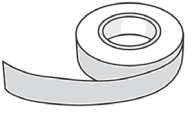

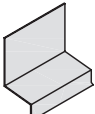
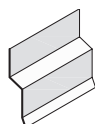





Table 2

Accessories/tools supplied by James Hardie			
Accessories	Description	Quantity/Size (approx)	Code
	Hardie™ Aluminium Radius External Box Corner A box corner mould to form the external joints. 9mm etch primed.	2750mm long 3000mm long 4000mm long	306215 306216 306217
	Hardie™ Aluminium Invert External Box Corner A corner mould to form the invert external joints. 9mm etch primed.	2750mm long 4000mm long	306213 306214
	Hardie™ 9mm Panel Aluminium Horizontal 'h' Mould A horizontal flashing to flash the horizontal joints. 9mm etch primed.	3000mm long	304508
	Aluminium 'h' Mould Jointer A jointer to cover the butt joint of 'h' mould.	100mm long	304512
	Hardie™ 9mm Panel Aluminium h External Corner Jointer 'h' mould external corner		305940
	Hardie™ 9mm Aluminium Angle T Socket A horizontal T flashing to flash the horizontal joints. 9mm etch primed.	3000mm long	306210
	Hardie™ Angle T Horizontal Jointer A jointer to cover the butt joint of T mould	100mm long	306221
	Hardie™ Angle T External Corner Jointer T mould external corner		306222
	Hardie™ 9mm Aluminium Internal Corner to join two 9mm panels at an internal corner	2750mm long 4000mm long	306218 306219
	uPVC Vent Strip Used to provide protection from vermin entering cavity space.	3000mm long	302490
	Inseal® 3259 Tape Black 50mm tape to be used under the vertical shiplap joint. Black 80mm tape to be used at corners.	50m roll	300767 300769
Tools			
	Hardie™ Blade Saw Blade Diamond tip 184mm diameter fibre cement circular saw blade. Spacers not included.	Each	300660

Table 3

Accessories/tools not supplied by James Hardie

James Hardie recommends the following products for use in conjunction with Axon™ Panel. James Hardie does not supply these products and does not provide a warranty for their use. Please contact component manufacturer for information on their warranties and further information on their products.

Accessories	Description
	<p>Flexible Underlay To comply with Table 23 of E2/AS1.</p>
	<p>Flexible Tape A flexible self-adhesive tape used in preparation of a window. Refer to the Window installation section in this manual for more information. e.g. Super-Stick Building Tape® by Marshall Innovations or 3M™ All Weather Flashing Tape 8067 by 3M™ Marshall Innovations: 0800 776 9727 3M™: 0800 474 787</p>
	<p>Joint Sealant Paintable flexible sealants are recommended for filling the joints. Refer to Section 7.2 for information. e.g. Sika® Sikaflex® MS, Sika® AT Facade, Bostik® Seal N Flex™-1 or similar</p>
	<p>Head Flashing Required over window heads to be supplied by window installer. Material must comply with Table 20 and 21 of E2/AS1.</p>
	<p>Flashing Material as per Table 20, 'E2/AS1'</p>
	<p>ND 50 Stainless Steel Brad Nails Used to install Axon™ Panel direct fix to timber framing. Used in a straight bradder.</p>
	<p>50 x 2.87mm Round Head Ring Shank Nail</p>
	<p>CRC® ADOS® Builders Fill Two part exterior grade fill to skim coat finish over brad nails.</p>
	<p>Dulux® Acrasand or Dulux® Sedona acrylic texture 0800 800 424</p>
	<p>Full mesh texture coating system e.g. STO®, or Resene® Construction Systems Texture coating system</p>
	<p>Stain Timbakote®, suitable for Axon™ Panel 133mm Grained Tel: 0800 846 225</p>

1.3 Manufacturing and Classification

Axon™ Panel is an advanced lightweight cement composite building product. The basic composition is Portland cement, ground sand, cellulose fibre, water and proprietary additives. The panel are easily identified by the name 'Axon™ Panel' printed at regular intervals on the back face of panel. Axon™ Panel is sealed and primed on the face and back is clear sealed.

Axon™ Panel is manufactured in Australia to the to AS/NZS 2908.2 'Cellulose-Cement Products Part 2: Flat Sheets' (ISO 8336 'Fibre Cement Flat Panels') standards in New Zealand. James Hardie is an ISO 9001 'Telarc' certified manufacturer.

Axon™ Panel is classified Type A, Category 3 in accordance with AS/NZS 2908.2 "Cellulose-Cement Products".

For Safety Data Sheets (SDS) visit www.jameshardie.co.nz or Ask James Hardie on 0800 808 868.

Axon™ Panel cladding is defined as a Light Weight Wall Cladding (not exceeding 30kg/m²) as per the NZS 3604.

2 Application

2.1 Application

Axon™ Panel are classified as lightweight wall claddings suitable for residential and light commercial buildings using timber framing. Axon™ Panel are pre-sealed on the face to take a suitable paint finish in any colour.

This document is intended for use by architects, designers and specifiers who may be involved with the specification of Axon™ Panel.

For the use of Axon™ Panel outside the scope of this specification, the designer, architect or engineer must ensure that the applicable clauses of the New Zealand Building Code (NZBC) have been considered and the intent of their design meets the requirements of the NZBC. Project specific details that are not covered in this specification are required to be developed by the project designer/architect.

2.2 Scope

- The Axon™ Panel must be installed vertically.
- An external wall structure that complies with the NZBC for an existing building or new building where the designer and/or installer has established that the external wall frame is suitable for this cladding installation.

This specification for the use of Axon™ Panel is limited to buildings which fall within the scope limitations of 'Acceptable Solution E2/AS1 paragraph 1.1' of the New Zealand Building Code (NZBC).

This document is intended for use by architects, designers and specifiers who may be involved with the specification of Axon™ Panel.

This manual covers the use of Axon™ Panel direct fixed to framing used in external walls of timber framed buildings up to very high wind zone.

Please refer to E2/AS1 for further information regarding the selection of construction methods to be used for fixing claddings.

Note: Refer to Axon™ Panel Timber Cavity Batten technical specification when fixing to timber cavity battens or Axon™ Panel Hardie™ CLD™ Structural Cavity Batten technical specification when fixing to Hardie™ CLD™ Structural Cavity Batten or for the installation of Axon™ Panel Brushed Concrete.

2.3 Details

Various Axon™ Panel figures are provided in the Details section of this document. This specification and details in dwg, dxf, jpg and pdf file format are also available for download at www.jameshardie.co.nz.

All dimensions shown are in millimetres unless noted otherwise.

3 Design

3.1 Compliance

Axon™ Panel installed in accordance with this specification has been tested and meets the requirements of clauses E2, B1, B2 and F2 of the NZBC.

When installed in accordance with the conditions of CodeMark number CMNZ30165 Axon™ Panel complies with all relevant requirements of the NZBC. Please refer to www.building.govt.nz or www.jameshardie.co.nz for a copy of the certificate.



Axon™ Panel technical specification has been BRANZ appraised. Appraisal No. 1211 (2022). Please refer to our website www.jameshardie.co.nz for a copy of the BRANZ appraisal 1211(2022).



4 Design

4.1 Responsibility

The specifier or other party responsible for the project must run through a risk matrix analysis to determine which construction method is to be used. The designer must also ensure that the figures published in this specification are appropriate for the intended application and that additional detailing is performed for specific design or any areas that fall outside the scope of this specification. The designers should ensure that the intent of their design meets the requirements of the NZBC.

Specifier

If you are a specifier or other responsible party for a project, ensure that the information in this document is appropriate for the application you are planning and that you undertake specific design and detailing for areas which fall outside the scope of these specifications.

Installer

If you are an installer ensure that you follow the design, moisture management principles, associated details and material selection provided by the designer. All of the details provided in this document must be read in conjunction with this specification.

Make sure your information is up to date

When specifying or installing Hardie™ fibre cement products, ensure you have the current manual. If you're not sure you do, or you need more information, visit www.jameshardie.co.nz or Ask James Hardie™ on 0800 808 868.

All New Zealand Standards referenced in this manual are current edition and must be complied with.

James Hardie conducts stringent quality checks to ensure that any product manufactured falls within our quality spectrum. It is the responsibility of the builder to ensure that the product meets aesthetic requirements before installation. James Hardie will not be responsible for rectifying obvious aesthetic surface variations following installation.

4.2 Clearances

The clearance between the bottom edge of cladding and paved/unpaved ground must comply with section 9.1.3 of E2/AS1. The finished floor level must also comply with these requirements. These clearances must be maintained throughout the life of the building.

Axon™ Panel must overhang the bottom plate on a concrete slab by a minimum of 50mm as required by NZS 3604.

Axon™ Panel must have a minimum clearance of 100mm from paved ground, and 175mm from unpaved ground.

On roofs and decks, the minimum clearance must be 50mm.

Do not install external cladding such that it may remain in contact with water or ground.

4.3 Structure

4.3.1 Timber Framing

Timber framed buildings must be designed in accordance with the NZS 3604 (Timber-framed buildings). When the framing is provided as per the (SED) specific engineering design, the framing stiffness must be either equivalent to or more than the stiffness requirements of the NZS 3604.

For timber frame walls longer than 12m it is best practice to allow for construction joints to accommodate movements generated due to timber shrinkage or deflections etc.

4.3.2 Wind Loading

Axon™ Panel is suitable for use in all wind zones in New Zealand up to and including VH for buildings as defined in NZS 3604.

4.4 Moisture Management

It is the responsibility of the specifier to identify moisture related risks associated with any particular building design.

Wall construction design must effectively manage moisture, considering both the interior and exterior environments of the building, particularly in buildings that have a higher risk of wind driven rain penetration or that are artificially heated or cooled.

Walls must include those provisions as required by the NZBC Acceptable Solution E2/AS1 'External Moisture'. In addition all wall openings, penetrations, junctions, connections, window sills, heads and jambs must incorporate appropriate flashings for waterproofing. The other materials, components and installation methods used to manage moisture in external walls, must comply with the requirements of relevant standards and the NZBC.

For further guidance on designing for weathertightness refer to BRANZ Ltd, and the Ministry of Business Innovation and Employment (MBIE) updates on the following websites respectively, www.branz.co.nz and www.building.govt.nz

4.5 Energy Efficiency

External walls constructed as per this technical specification, using Axon™ Panel cladding must use suitable bulk insulation to meet the minimum thermal insulation requirements as per Clause H1/AS1 'Energy Efficiency' of the NZBC.

4.6 Bracing

Axon™ Panel direct fixed can be used to achieve structural bracing when fixed with stainless steel Hardie™ Flex nails. For further information refer to the Bracing Design Manual by James Hardie.

4.9 Fire Rated Walls

Axon™ Panel when direct fixed with Hardie™ Flex nails to external walls can achieve fire ratings up to 60/60/60 to comply with C/AS1 of the NZBC when the walls are constructed in accordance with the current 'Fire and Acoustic Design Manual' by James Hardie.

Axon™ Panel are suitable for use where non-combustible materials are required on walls close to boundary.

Nogs in fire rated walls must be at 800mm centres maximum

4.11 Steel Framing

Refer to Steel Frame Technical Supplement by James Hardie about the installation of Axon™ Panel to steel frame.

4.12 Construction Methods

Buildings with a risk score of 1-6 calculated in accordance with the NZBC Solution 'E2/AS1' Table 2, Axon™ Panel can be direct fixed. The following framing is required for direct fixed construction method:

- Studs at 600mm centres maximum
- A minimum 90 x 45mm framing size is required
- Nogs/dwangs to suit the site framing requirements

4.13 Tolerances

In order to achieve the required performance and an acceptable wall finish, it is imperative that framing is straight and true.

Framing tolerances must comply with the requirements of NZS 3604. All framing shall be made flush.

5 Safe Working Practices

WARNING - DO NOT BREATHE DUST AND CUT ONLY IN WELL VENTILATED AREA

Hardie™ fibre cement products contain sand, a source of respirable crystalline silica

May cause cancer if dust from product is inhaled. Causes damage to lungs and respiratory system through prolonged or repeated inhalation of dust from product.

Intact fibre cement products are not expected to result in any adverse toxic effects. The hazard associated with fibre cement arises from the respirable crystalline silica present in dust generated by activities such as cutting, rebating, drilling, routing, sawing, crushing, or otherwise abrading fibre cement, and when cleaning up, disposing of or moving dust.

When doing any of these activities in a manner that generates dust, follow James Hardie instructions and best practices to reduce or limit the release of dust.

If using a dust mask or respirator, use an AS/NZS 1716 P1 filter and refer to Australian/New Zealand Standard 1715:2009 Selection, Use and Maintenance of Respiratory Protective Equipment for more extensive guidance and more options for selecting respirators for workplaces. For further information, refer to our installation instructions and Safety Data Sheets available at www.jameshardie.co.nz.

FAILURE TO ADHERE TO OUR WARNINGS, SAFETY DATA SHEETS, AND INSTALLATION INSTRUCTIONS MAY LEAD TO SERIOUS PERSONAL INJURY OR DEATH.

Crystalline Silica is

- Commonly known as sand or quartz
- Found in many building products e.g. concrete, bricks, grout, wallboard, ceramic tiles, and all fibre cement materials

Why is Crystalline Silica a health hazard?

- Silica can be breathed deep into the lungs when present in the air as a very fine (respirable) dust
- Exposure to silica dust without taking the appropriate safety measures to minimise the amount being breathed in, can lead to a potentially fatal lung disease – silicosis – and has also been linked with other diseases including cancer. Some studies suggest that smoking may increase these risks
- The most hazardous dust is the dust you cannot see!

When is Crystalline Silica a health hazard?

- It's dangerous to health if safety protocols to control dust are not followed when cutting, drilling or rebating a product containing crystalline silica and when cleaning up
- Products containing silica are harmless if intact (e.g. an un-cut sheet of wall board)

Avoid breathing in crystalline silica dust

Safe working practices

- ✗ NEVER use a power saw indoors or in a poorly ventilated area
- ✗ NEVER dry sweep
- ✓ ALWAYS use M Class or higher vacuum or damp down dust before sweeping up
- ✗ NEVER use grinders
- ✓ ALWAYS use a dust reducing circular saw equipped with a sawblade specifically designed to minimise dust creation when cutting fibre cement – preferably a sawblade that carries the Hardie™ Blade name or one with at least equivalent performance – connected to an M Class or higher vacuum
- ✓ Before cutting warn others in the area to avoid dust
- ✓ ALWAYS follow tool manufacturers' safety recommendations
- ✓ ALWAYS expose only the minimum required depth of blade for the thickness of fibre cement to be cut
- ✓ ALWAYS wear a properly-fitted, approved dust mask or respirator P1 or higher in accordance with applicable government regulations and manufacturer instructions
- ✓ Consider rotating personnel across cutting tasks to further limit respirable silica exposures.

When cutting Axon™ Panel:

- ✓ Work outdoors only
- ✓ Make sure you work in a well ventilated area
- ✓ Position cutting station so wind will blow dust away from yourself and others in the working area
- ✓ Rotate employees across cutting task over duration of shift
- ✓ Cut products with a Hardie™ Blade Saw Blade (or equivalent) and a dust reducing circular saw connected to a M Class or higher vacuum
- ✓ When sawing, sanding, rebating, drilling or machining fibre cement products, always:
 - Wear your P1 or higher (correctly fitted in accordance with manufacturers' instructions), ask others to do the same.
 - Keep persons on site at least 2 metres and as far as practicable away from the cutting station while the saw is in operation
 - If you are not clean shaven, then use a powered air respirator with a loose fitting head top
 - Wear safety glasses
 - Wear hearing protection
- ✓ Make sure you clean up BUT never dry sweep. Always hose down with water/wet wipe or use an M Class or higher vacuum

Working Instructions

Hardie™ Blade Saw Blade

The Hardie™ Blade Saw Blade used with a dust-reducing saw is ideal for fast, clean cutting of Hardie™ fibre cement products. A dust-reducing saw uses a dust collector connected to a M Class or higher vacuum. When sawing, clamp a straight edge to the sheet as a guide and run the saw base plate along the straight edge when making the cut.

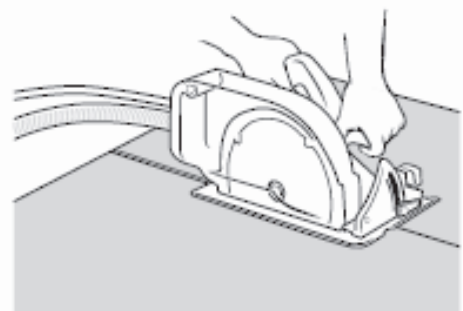

Hole-Forming

For smooth clean cut circular holes:

- Mark the centre of the hole on the sheet
- Pre-drill a 'pilot' hole
- Using the pilot hole as a guide, cut the hole to the appropriate diameter with a hole saw fitted to a heavy duty electric drill

For irregular holes:

- Small rectangular or circular holes can be cut by drilling a series of small holes around the perimeter of the hole then tapping out the waste piece from the sheet face
- Tap carefully to avoid damage to sheets, ensuring that the sheet edges are properly supported

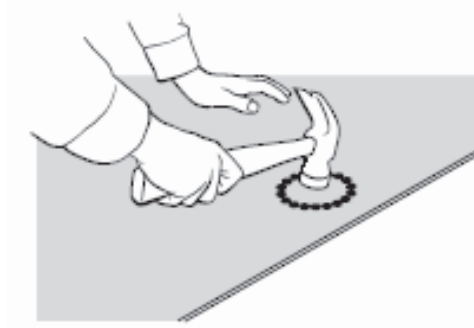

5.1 Storage and Delivery

Keeping products and people safe

Off loading

- ✓ Hardie™ fibre cement products should be off-loaded carefully by hand or by forklift
- ✓ Hardie™ fibre cement products should not be rolled or dumped off a truck during the delivery to the jobsite

Storage

Hardie™ fibre cement products should be stored:

- ✓ In their original packaging
- ✓ Under cover where possible or otherwise protected with a waterproof covering to keep products dry
- ✓ Off the ground – either on a pallet or adequately supported on timber or other spacers
- ✓ Flat so as to minimise bending

Hardie™ fibre cement products must not be stored:

- ✗ Directly on the ground
- ✗ In the open air exposed to the elements

James Hardie is not responsible for damage due to improper storage and handling.

5.2 Tips for safe and easy handling of Axon™ Panel

- ✓ Carry with two people
- ✓ Hold near each end and on edge
- ✓ Exercise care when handling sheet products to avoid damaging the edges/corners

6 Installation

6.1 General

This Axon™ Panel technical specification is only suitable for timber-framed buildings. Other framing materials are subject to a specific engineering design.

Axon™ Panel must be kept dry and under cover whilst in storage or during the installation. Every endeavour must be made to keep framing dry once panel fixing commences. All site-cut panel edges must be sealed prior to installation.

- The shiplap jointing of panels is only suitable for vertical fixing of panels.
- Ensure the sheets are from the same batch.
- It is recommended to fix from the centre of the panel and work outwards.
- Do not overdrive fasteners.
- Round head gun nails to be finished tight with the panel surface.
- Do not fix in the groove of Axon™ Panel.
- Hardie™ Flex nails must be finished flush with the panel surface.
- Minimum sheet width around window/door openings or corners etc. to be 200mm

6.2 Timber Framing

6.2.3 Durability

The external framing must be treated to a minimum H1.2 treatment. Higher treatment levels may be used, but check for the compatibility of treatment chemicals with other materials. Refer to the NZBC Acceptable Solution B2/AS1 'Durability' for further information about the durability requirements.

For timber treatment and allowable moisture content information refer to the NZS 3602 (Timber and Wood-Based Products for use in Buildings) and NZS 3640 (Chemical Preservation of Round Sawn Timber) for minimum timber treatment selection and treatment requirements.

Also refer to the framing manufacturer's literature for further guidance on timber selection. Framing must be protected from moisture at site in accordance with the recommendation of the framing manufacturers.

6.2.4 Frame Construction

The framing must fully support all panel edges. The framing must be rigid and not rely on the cladding panel for stability.

Timber framing sizes and its set-out must comply with NZS 3604 or specific engineering design requirements and as specified in this specification.

In case of gable end trusses sitting on top plates of the external wall frame, the frame size must comply with the minimum timber sizes stipulated for wall frames in Section 8 of the NZS 3604.

For timber frame walls longer than 12m, it is best practice to allow for construction joints to accommodate movements generated due to timber shrinkage or deflections generated by loadings etc.

6.3 Flexible Underlay or HomeRAB™ Pre-Cladding

Flexible underlay or HomeRAB™ Pre-Cladding must be provided as per the requirements of the NZBC Acceptable Solution E2/AS1 'External Moisture' and NZS 3604. The flexible underlay must comply with Table 23 of E2/AS1 and AS/NZS 4200.1. The flexible underlay must be fixed in accordance with E2/AS1, NZS 3604 and AS/NZS 4200.2 and the underlay manufacturer's recommendations.

Walls which are not lined on the inside face (e.g. garage walls or gable ends) must include a rigid sheathing or an air barrier behind the cladding which complies with the requirements of the NZBC Acceptable Solution E2/AS1 Table 23. For attached garages, flexible underlays must be selected in accordance with the NZBC Acceptable Solution E2/AS1, paragraph 9.1 3.4. HomeRAB™ Pre-Cladding is suitable for use in these applications. It must be installed in accordance with the HomeRAB™ Pre-Cladding/RAB™ Board installation manual.

6.4 Flashing

All wall openings, penetrations, intersections, connections, window sills, heads and jambs must be flashed prior to panel installation. Please refer to moisture management requirements in Clause 2.5. The flexible underlay, HomeRAB™ Pre-Cladding or RAB™ Board must be appropriately taped around the penetrations and lapped/taped to flashings. Materials must be lapped in such a way that water tracks down to the exterior of a building. James Hardie will assume no responsibility for water infiltration within the wall due to poor installation of flashings or flexible underlays. The selected flashing materials must comply with the durability requirements of the NZBC. For information refer to Table 20 of clause E2 of the NZBC.

When using a HomeRAB™ Pre-Cladding/RAB™ Board the entire framing around window opening must be sealed with a flashing tape. The tape must be finished over the face of the HomeRAB™ Pre-Cladding or RAB™ Board. The flashing tapes like Thermaflash® Self Adhesive Window Flashing Tape by Thermakraft™, Super-Stick Building Tape® by Marshall Innovations or 3M™ All Weather Flashing Tape 8067 by 3M™ are recommended for use with HomeRAB™ Pre-Cladding/RAB™ Board. Refer to the tape manufacturer's literature for further information regarding their installation.

6.5 Junctions and Penetrations

Refer to Clause 2.5 of this specification for moisture management requirements. All windows and doors must be detailed as per the requirements of this specification. James Hardie has developed the window details for Axon™ Panel which meet the requirements of E2 'External Moisture', an approved document of the NZBC. Refer to Figures 17 to 19.

6.6 Control of External Fire Spread

Axon™ Panel has been assessed as per Appendix C C7.1.1 and is suitable for use where 'Non-Combustible Material' are specified for use in external wall cladding applications and complies with requirements of Paragraph 5.4 of the NZBC Acceptable Solutions C/AS1 and Paragraph 5.8.1 of Acceptable Solutions C/AS2 of the NZBC.

6.7 Resistance to Moisture/Rotting

Axon™ Panel has demonstrated resistance to permanent moisture induced deterioration (rotting) and has passed the following tests in accordance with AS/NZS 2908.2:

- Heat Rain (Clause 6.5).
- Water Permeability (Clause 8.2.2).
- Warm Water (Clause 8.2.4).
- Soak Dry (Clause 8.2.5).

6.8 Alpine Regions

In regions subject to freeze/thaw conditions, Axon™ Panel must not be in direct contact with snow or ice build up for extended periods, e.g. external walls in alpine regions must be protected where snow drifts over winter are expected.

The Axon™ Panel has been tested in accordance with AS/NZS 2908.2 Clause 8.2.3.

6.9 Fastener Durability

Fasteners must meet the minimum durability requirements of the NZBC. NZS 3604 specifies the requirements for fixing material to be used in relation to exposure conditions and are summarised in Table 2.

Table 2

Exposure conditions and nail selection prescribed by NZS 3604		
Zone	Application	
D (sea spray) and geothermal hot spots	General	Stainless steel 304/316
	Fire	
	Bracing	
C and B*	General	Hot dip galvanised **
	Fire	

* Zone C areas where local knowledge dictates that increased durability is required, appropriate selection shall be made. Microclimate conditions as detailed in the NZS 3604, Paragraph 4.2.4 require SED.

**Hot dip galvanised must comply with AS/NZS 4680.

Also refer to the NZBC Acceptable Solution E2/AS1 Table 20 and 21 for information regarding the selection of suitable fixing materials and their compatibility with other materials.

6.10 Fastener – Type, Size and Layout

6.10.1 Direct Fix

Axon™ Panel must be fixed to framing using the fixings as specified in Table 3 below and follow the edge distance required for nails as shown in the details. Refer to Figures 2, 4 and 5.

Table 3

Panel fixing	
Direct fixed to frame using Hardie™ Flex nails over flexible underlay	
40 x 2.8mm Hardie™ Flex nails	Fix at 200mm centres to all framing. Stud width 45mm min. required at vertical joint.
Direct fixed to frame using brad nail over flexible underlay	
ND 50 stainless steel straight brad nail	Fix at 150mm centres to all framing. Studs width 45mm min. required at vertical joint.

Notes:

1. Brad nail fixing method is only suitable up to very high wind speed zones. Do not use this method for EH wind zones or for bracing/fire rating application..
2. Hardie™ Flex nails must be finished flush with panel surface.
3. Round head gun nails to be finished tight with panel surface.
4. Special fixing arrangements are required for bracing and fire-resistance rated wall systems. Fixings are 150 around the perimeter and to nogs and studs
5. When studs spaced at 400mm centres using Axon™ Panel 400mm Grooved. the nail fixings to intermediate studs to be offset 5mm from the groove in Panel.

For more information Ask James Hardie on 0800 808 868.

When fixing the panels using nail guns, refer to the nail gun manufacturer for information about nails and the type of nail gun to be used.

Note: Do not use 'D' head nails.

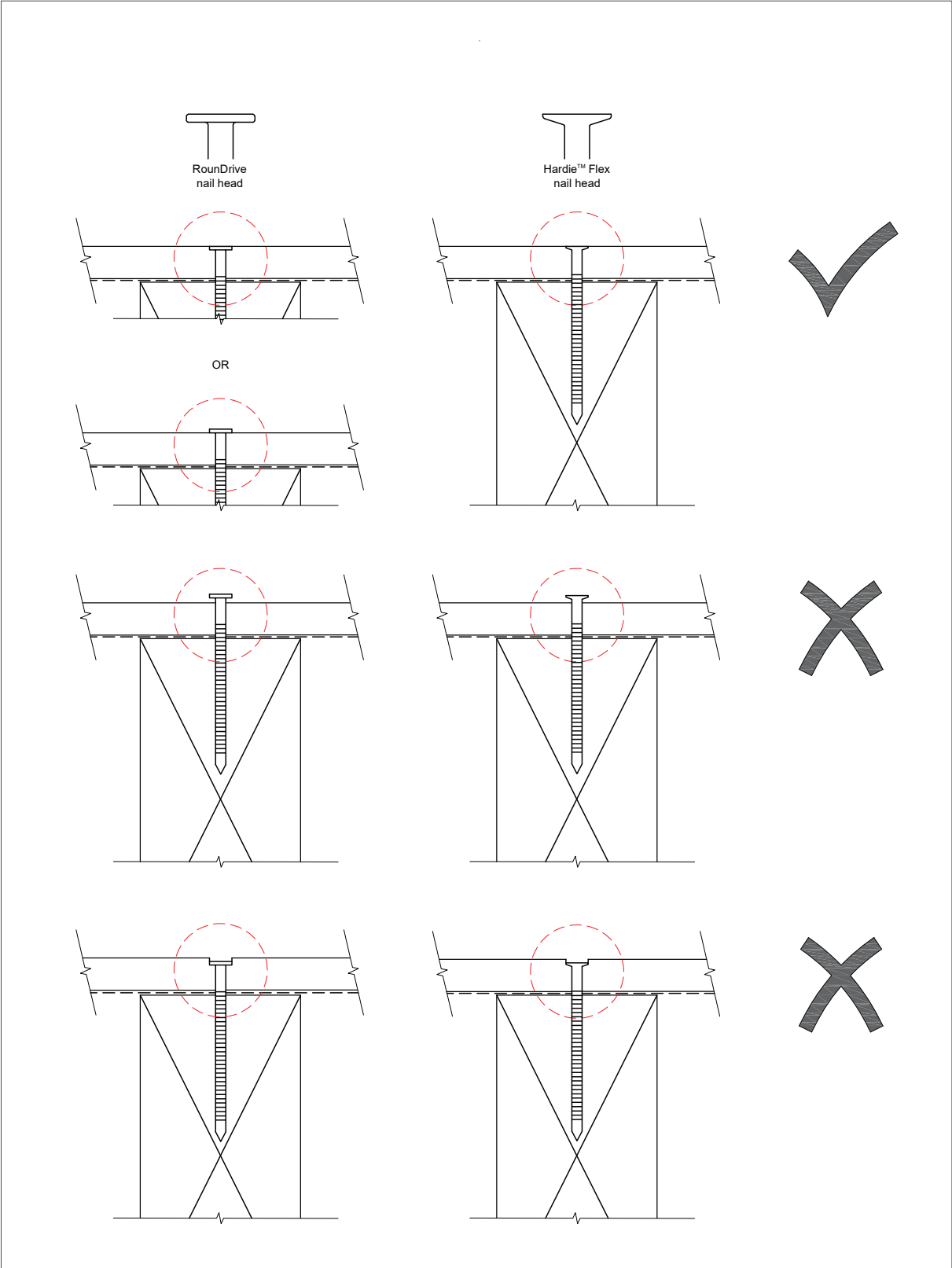

6.10.2 Cavity Construction using Timber Cavity Battens

When fixing Axon™ Panel using timber cavity battens, these details are available at www.jameshardie.co.nz or Ask James Hardie on 0800 808 868.

6.11 Panel Layout

All panel edges must be supported by the framing. The shiplap joint must be formed vertically. The framing centres must be checked before the panel installation.

The edge distance at panel corner must be minimum 75mm vertically from panel corners. Refer to Figure 2.

6.12 Vertical Joint

Axon™ Panel are shiplap jointed keeping a gap of 1-2mm between the panels. A 48mm wide 3259 Inseal® sealing tape is used under the joint over the face of the timber stud where direct fixed construction method is used. A flexible sealant must be applied to the full length of the shiplap joint before the panels are jointed. The edge distance for a Hardie™ Flex nail must be 18mm min. Refer to Figure 4 and 5. The edge distance for a brad nail must be 16mm and 18mm. Refer to Figure 29.

6.13 Horizontal Joint

At floor joist levels a horizontal joint must be provided to accommodate the movement resulting from timber joist shrinkage and settlement. A Hardie™ 9mm panel aluminium horizontal 'h' mould or angle 't' socket is used to form a horizontal joint respective. Use the aluminium 'h' mould or angle 't' socket jointer to cover over the butt joint of 'h' mould. A purpose made metal 'Z' flashing could also be used to flash the horizontal joint. Refer to Figures 20 - 25.

6.14 External Corner

A Hardie™ 9mm panel aluminium box corner mould is used to form the external box corner. The site-cut sheet edges must be sealed before butting them into the box corner. Refer to Figure 8.

On a two storey construction the aluminium box corner is finished under the aluminium 'h' mould. A Hardie™ 9mm aluminium 'h' mould external corner must be used over the corner when in this situation. Refer to Figure 24.

6.15 Internal Corner

Direct fixed internal corner is formed using a Hardie™ 9mm aluminium internal corner. Refer to Figure 7.

6.16 Flashing Material Durability

Please refer to Table 20 of E2/AS1 of the NZBC regarding the durability requirements of various flashing materials.

6.17 Board and Batten Look

In order to achieve a board and batten look, Hardie™ Axent™ Trim can be fixed vertically over the panel surface.

The trims can be placed to suit the project's aesthetic requirements. However, we recommend the trim spacing @ 200mm centres minimum is maintained between the trims. For any closer spacing of trims, Ask James Hardie™ on 0800 808 868 for assistance.

Refer to Figures 10 - 15 for information.

7 Finishing

7.1 Preparation

Painting of Axon™ Panel is mandatory to meet the durability requirements of the NZBC and 15 year James Hardie product warranties. Axon™ Panel must be dry and free of any dust or grime before painting. The panels must be painted within 90 days of their installation. There is no restriction on the LRV of paint to be applied on the Axon™ Panel.

Dark paints can be used when using the aluminium flashings.

Panels are pre-primed and are suitable for site applied acrylic paints. Pre-finished panels can also be installed using exposed head fasteners.

In order to seal cut edges or sanded patches, Dulux® 1 Step, Resene® quick dry, Taubmans® Underproof Acrylic Primer Undercoat or a similar product should be applied. The primer should be compatible with the paint to be used.

Where panels are fixed with brad nails, the nail heads must be finished flush with panel surface. The nail gun should be set to nail “proud” of the panel surface and nail heads to be manually finished flush with surface. The nail heads can be skimmed over with an exterior grade 2 part builders fill if required. The skimmed area must be primed prior to site-applied finishing.

For site-applied finishes where brad nails are used. James Hardie recommends an undercoat and a minimum of two coats of acrylic paint. Follow the paint manufacturer’s recommendations to prepare the surface and to adequately cover and conceal the panel fixings.

For best aesthetic results a low sheen paint is recommended.

7.2 Coating

7.2.1 Paint

Axon™ Panel are supplied pre-primed. Panels must be painted within 90 days of installation. Use only quality exterior paints complying with AS 3730. Manufacturer’s specification for the selected paint must be followed.

7.2.2 Staining - Only for Axon™ Panel Grained

Stains containing linseed oil are specifically designed for wood and may not be suitable for fibre cement cladding products, primed or unprimed. Semi-transparent stains can vary in uniformity of appearance depending on method of application and conditions, requiring a high level of skill and craftsmanship to achieve a uniform appearance. Clear coats have not proven durable in exterior exposure and James Hardie considers them a maintenance item that may require application of a refurbishing sealer at regular intervals. James Hardie does not warrant the appearance and durability of the use of semi-transparent stains and clear coats.

For further information contact the stain manufacturers. Refer to Section 11 for stain manufacturer details.

7.2.3 Roll on Texture - Only for Axon™ Panel Smooth

Axon™ Panel Smooth can be finished with rolled on texture acrylic texture coatings. Panels are supplied pre-primed and are ready for acrylic textures to be applied directly to it. Acrylic texture products are available in a range of textures that vary from fine finish to rough texture for a fast application on site. Refer to Dulux® or other similar texture coating suppliers for further information.

7.3 Flexible Sealant

All sealants used must comply with the relevant requirements of the NZBC. Their application and usage must be in accordance with manufacturer’s instructions. Check with sealant manufacturer prior to coating over sealants. Some sealant manufacturers do not recommend coating over their products.

8 Care and Maintenance

The extent and nature of maintenance will depend on the geographical location and exposure of the building. As a guide, it is recommended that basic normal maintenance tasks shall include but not be limited to:

- Washing down exterior surfaces every 6-12 months using low pressure water and a brush, and every 3-4 months in extreme coastal conditions or sea spray zones. Refer to your paint manufacturer for wash down requirements and do not use a water blaster to wash down the cladding.
- Re-applying of exterior protective finishes if necessary. Always refer to your paint manufacturer for re-coating requirements.
- Maintaining the exterior envelope and connections including joints, penetrations, flashings and sealants that may provide a means of moisture entry beyond the exterior cladding.
- Cleaning out gutters, blocked pipes and overflows as required
- Pruning back vegetation that is close to or touching the building
- The clearance between the bottom edge of Axon™ Panel and the finished ground must always be maintained.

9 Product information

9.1 Manufacturing and Classification

Axon™ Panel is an advanced lightweight cement composite building product. The basic composition is Portland cement, ground sand, cellulose fibre, water and proprietary additives. The panels are easily identified by the name 'Axon™ Panel' printed at regular intervals on the back face of panel. Axon™ Panel is sealed and primed on the face and back is clear sealed.

Axon™ Panel are manufactured in Australia to the to AS/NZS 2908.2 'Cellulose-Cement Products Part 2: Flat Sheets' (ISO 8336 'Fibre Cement Flat Panels') standards in New Zealand. James Hardie is an ISO 9001 'Telarc' certified manufacturer.

Axon™ Panel is classified Type A, Category 3 in accordance with AS/NZS 2908.2 "Cellulose-Cement Products".

For Safety Data Sheets (SDS) visit www.jameshardie.co.nz or Ask James Hardie on 0800 808 868.

10 Details

The following generic details have been provided in this document for both direct fixed and cavity construction methods.

Table 8

Description	Page
Figure 1: Direct fixed typical framing setout	23
Figure 2: Direct fixed typical panel Hardie™ Flex nail fixing setout	24
Figure 3: Direct fixed foundation detail	25
Figure 4: Axon™ Panel vertical shiplap joint — Hardie™ Flex nail	26
Figure 5: Axon™ Panel Smooth vertical shiplap joint - Hardie™ Flex nail	27
Figure 6: Vertical sealant joint	28
Figure 7: Internal corner detail	29
Figure 8: External corner radius detail	30
Figure 9: External corner invert detail	31
Figure 10: Hardie™ Axent™ Trim at joint	32
Figure 11: Hardie™ Axent™ Trim 70 or 89mm intermediate framing	33
Figure 12: Hardie™ Axent™ Trim 45mm intermediate framing	34
Figure 13: Hardie™ Axent™ Trim fixing	35
Figure 14: Hardie™ Axent™ Trim at internal corner	36
Figure 15: Hardie™ Axent™ Trim at external corner	37
Figure 16: Soffit detail	38
Figure 17: Window head	39
Figure 18: Section at sill	40
Figure 19: Window jamb	41
Figure 20: Horizontal joint detail	42
Figure 21: Aluminium 'H' mould joiner	43
Figure 22: Horizontal joint detail with 'T' socket	44
Figure 23: Angle 'T' horizontal joiner	45
Figure 24: Corner at 'H' mould joint detail	46
Figure 25: Corner at 'T' socket joint detail	47
Figure 26: Joining moulding	48
Figure 27: Cavity pipe penetration	49
Figure 28: Direct fixed typical panel brad nail fixing setout	50
Figure 29: Shiplap joint - brad nail	50

Figure 1: Direct fixed typical framing setout

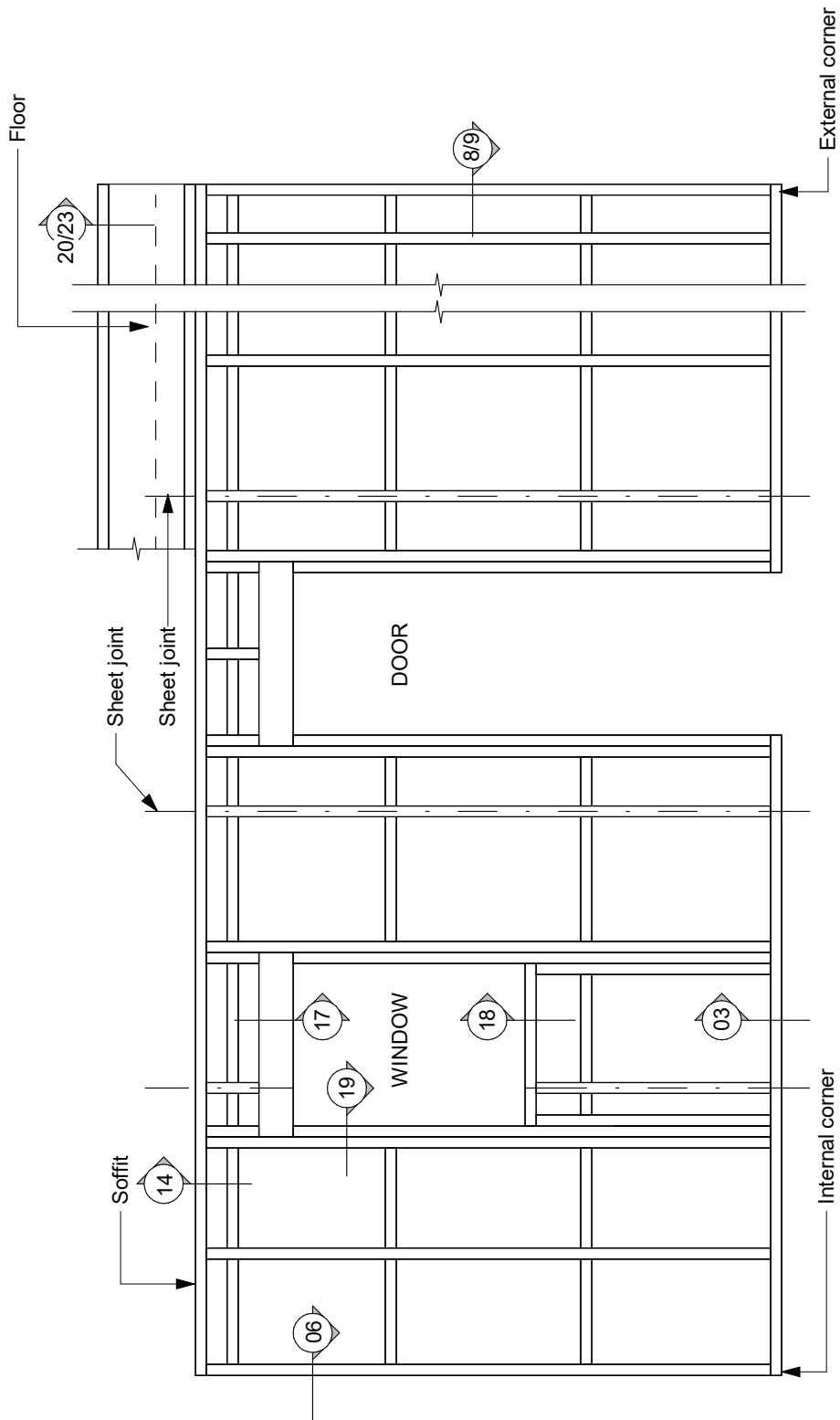

Note:
 * Maximum stud spacing 600mm centres
 * Check that the risk matrix score is 6 or less

Figure 2: Direct fixed typical panel Hardie™ Flex nail fixing setout

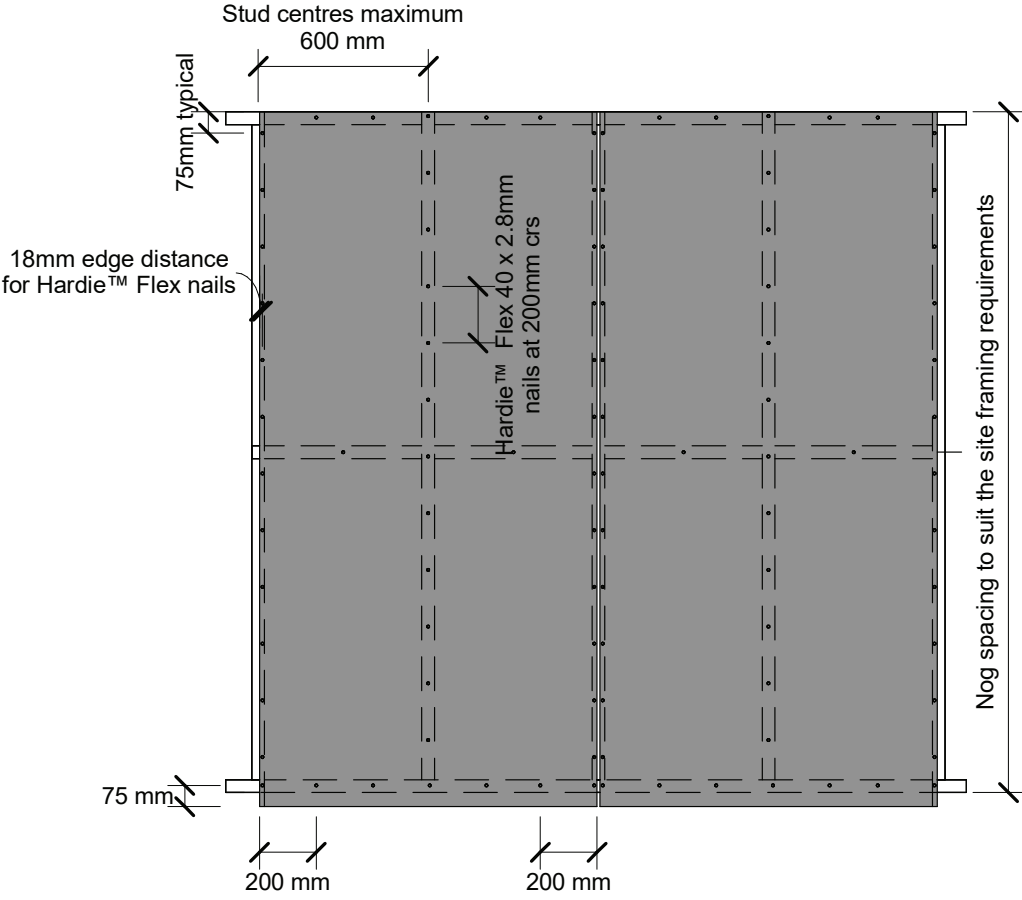

Note: When studs spaced at 400mm centres using Axon™ Panel 400, the nail fixings to intermediate studs to be offset 5mm from the groove in Panel.

Figure 3: Direct fixed foundation detail

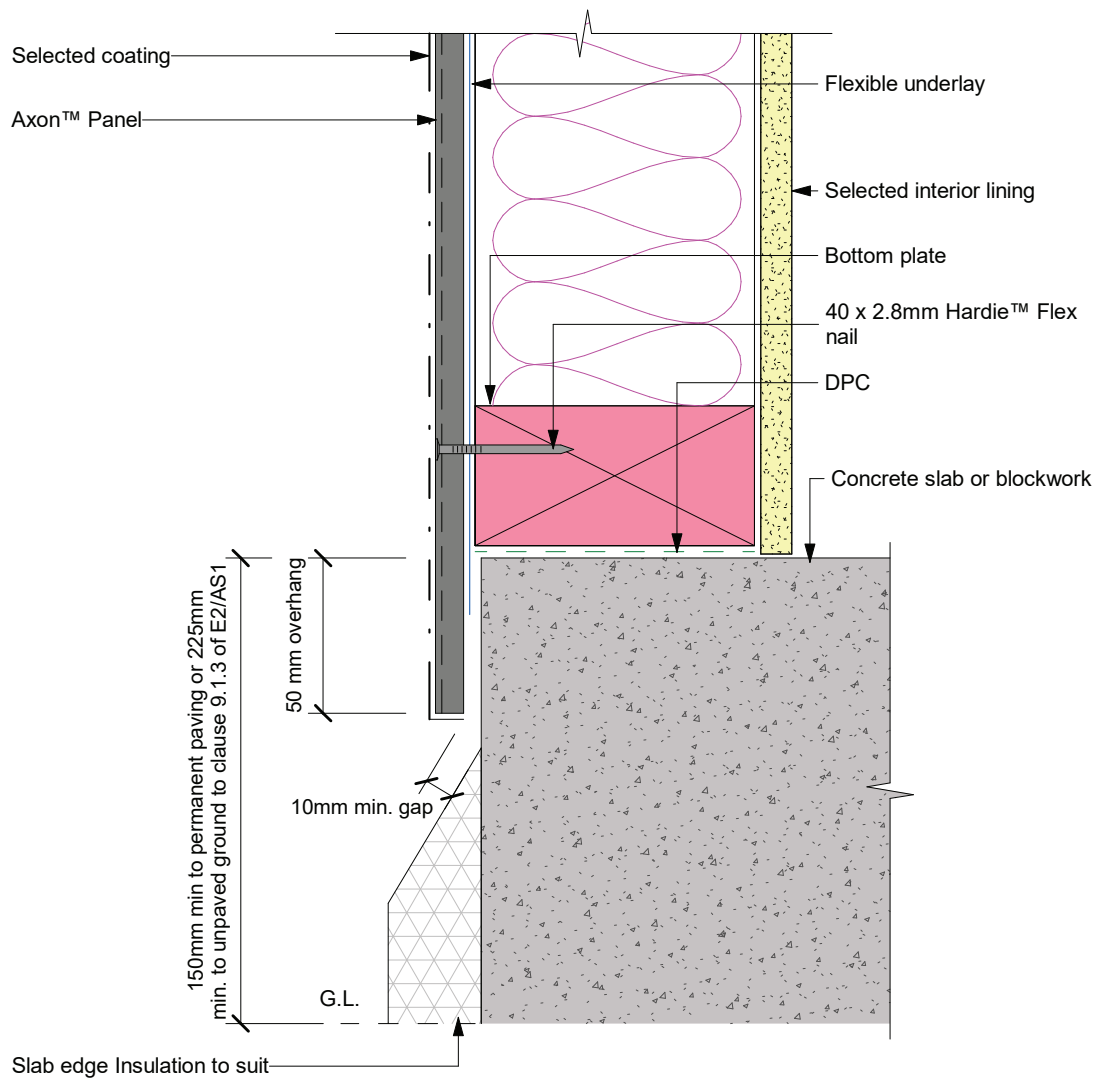

Note: Refer to Section 2.4 for further information

Figure 4: Axon™ Panel vertical shiplap joint — Hardie™ Flex nail

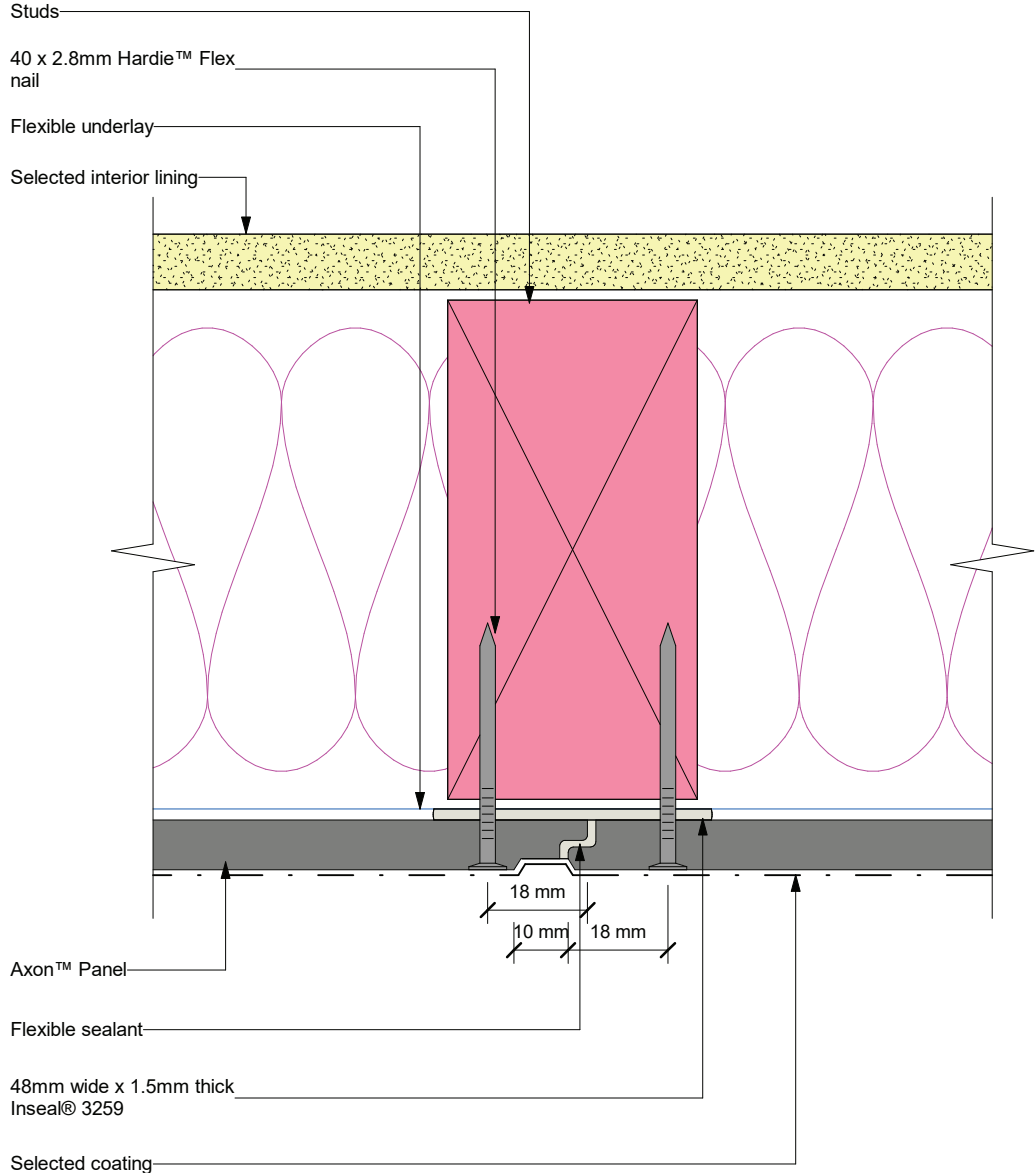

- Note:
- * Ensure that the required edge distance is maintained when fixing.
 - * Seal cut edges with a primer compatible with final coatings.

Figure 5: Axon™ Panel Smooth vertical shiplap joint - Hardie™ Flex nail

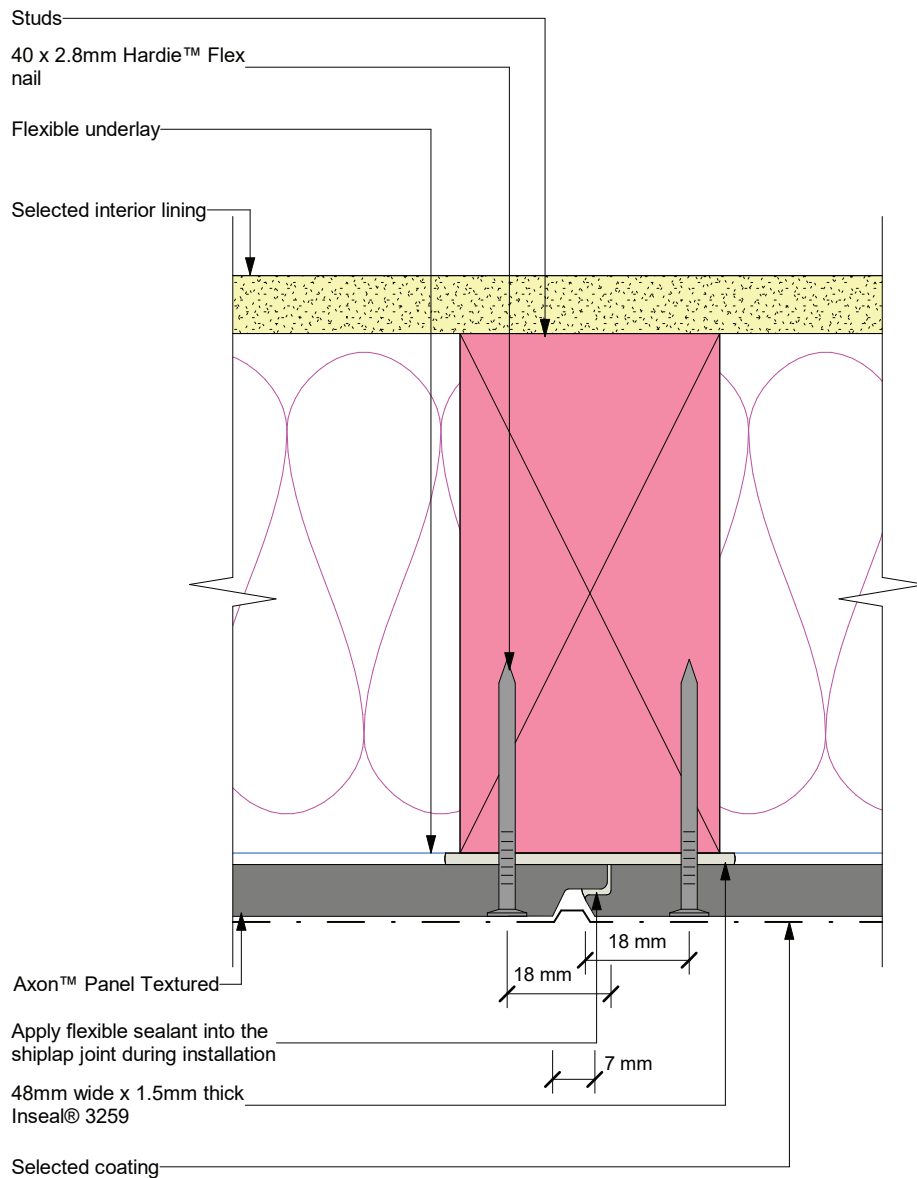

Note:

- * Ensure that the required edge distance is maintained when fixing.
- * Seal cut edges with a primer compatible with final coatings.

Figure 6: Axon™ Panel shiplap joint - Hardie™ Flex Nail

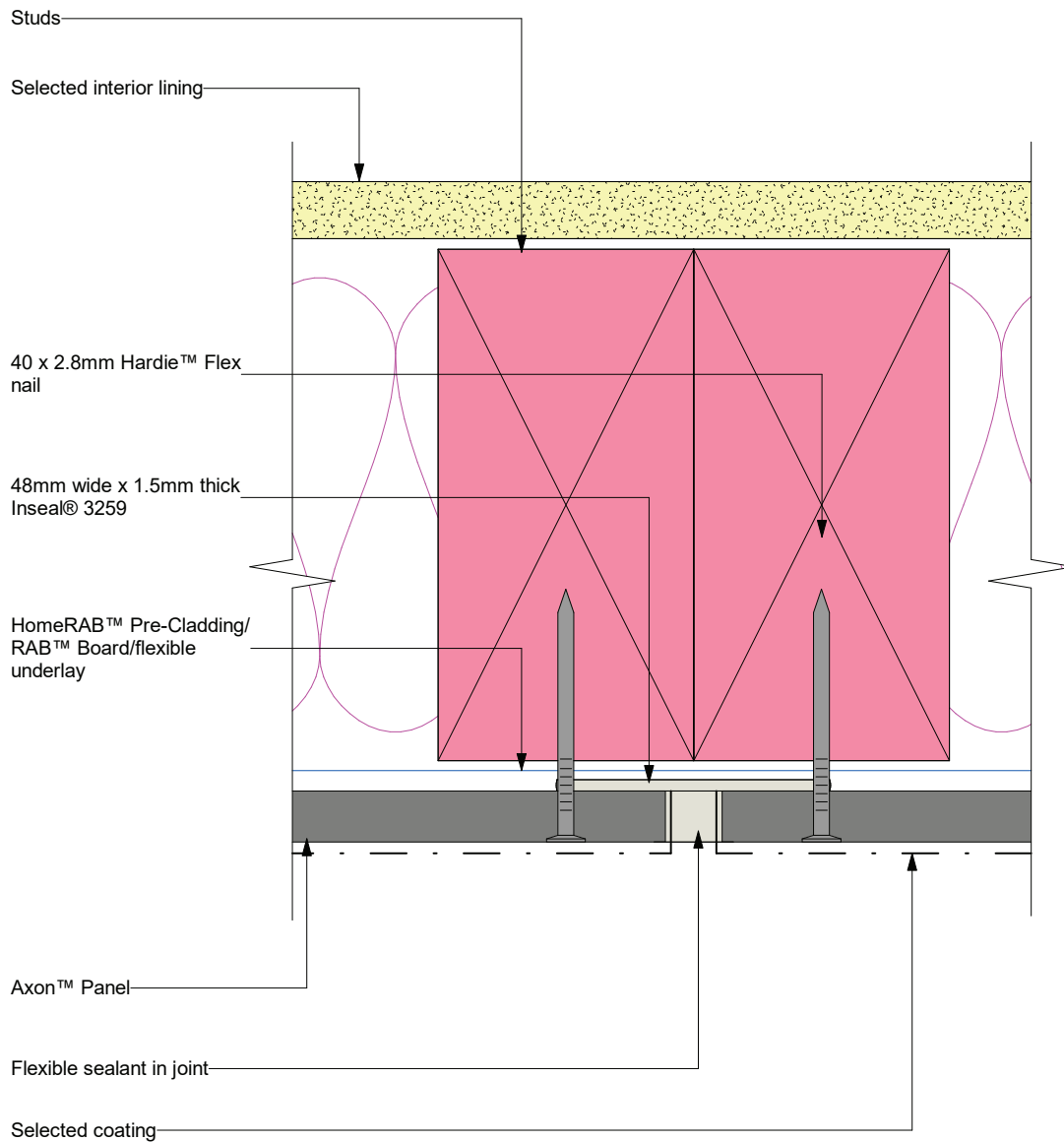

Note:

- * Ensure that the required edge distance is maintained when fixing.
- * Seal cut edges with a primer compatible with final coatings.

For use ONLY where manufactured edge jointing not possible for build ie small window in full sheet

Figure 7: Internal corner detail

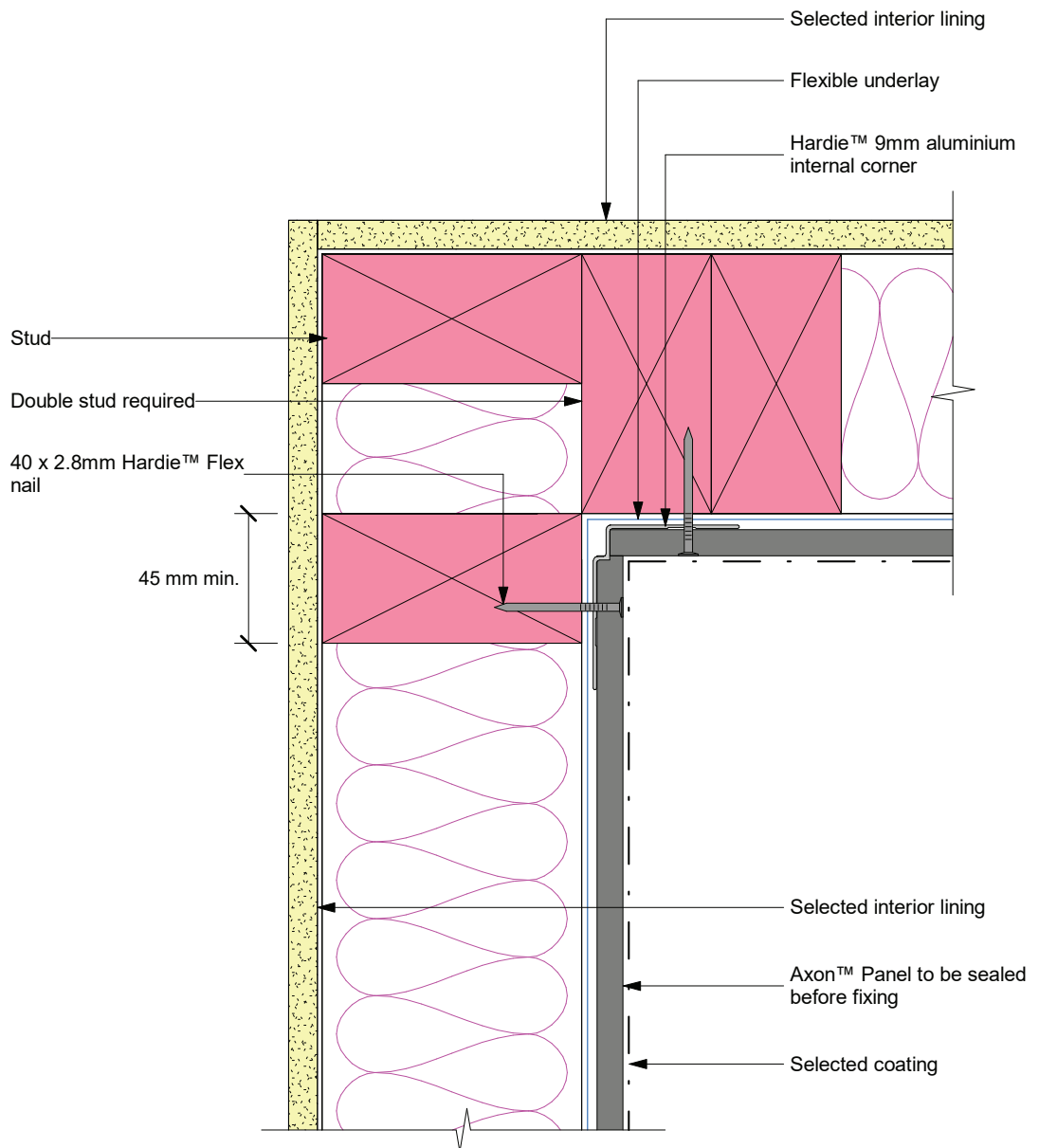
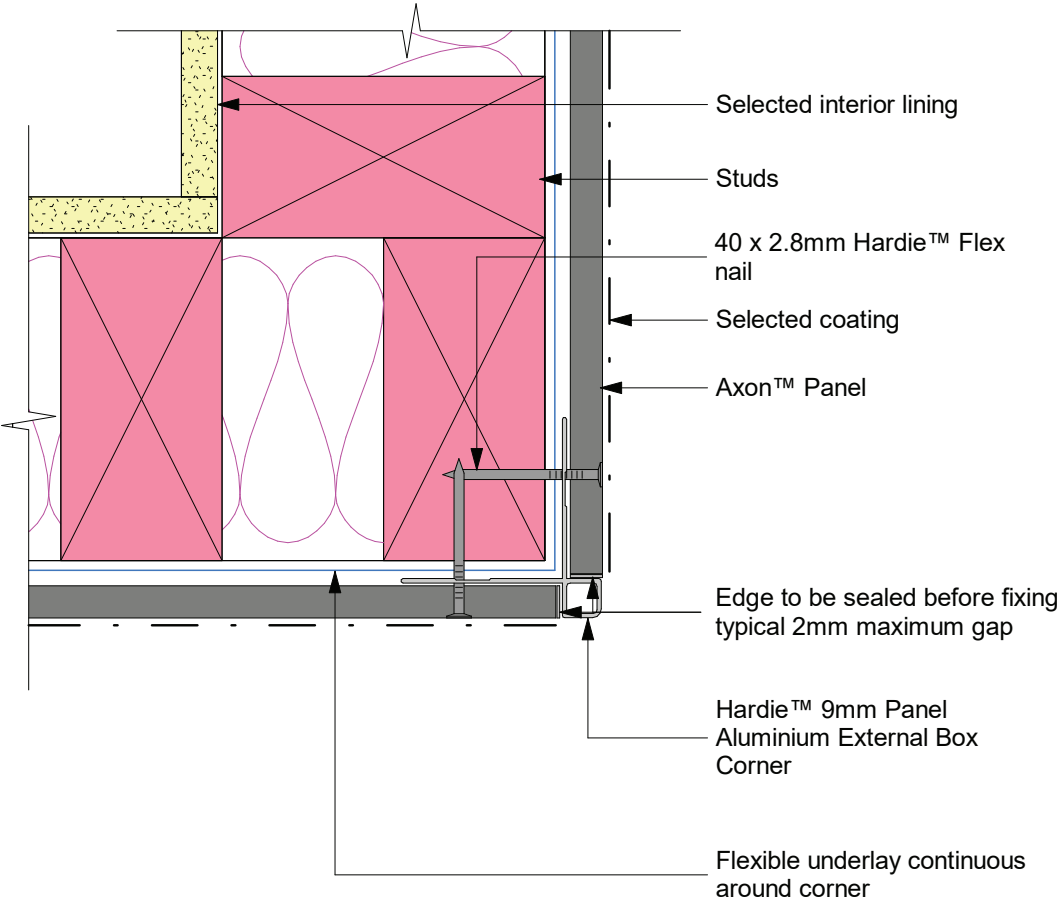
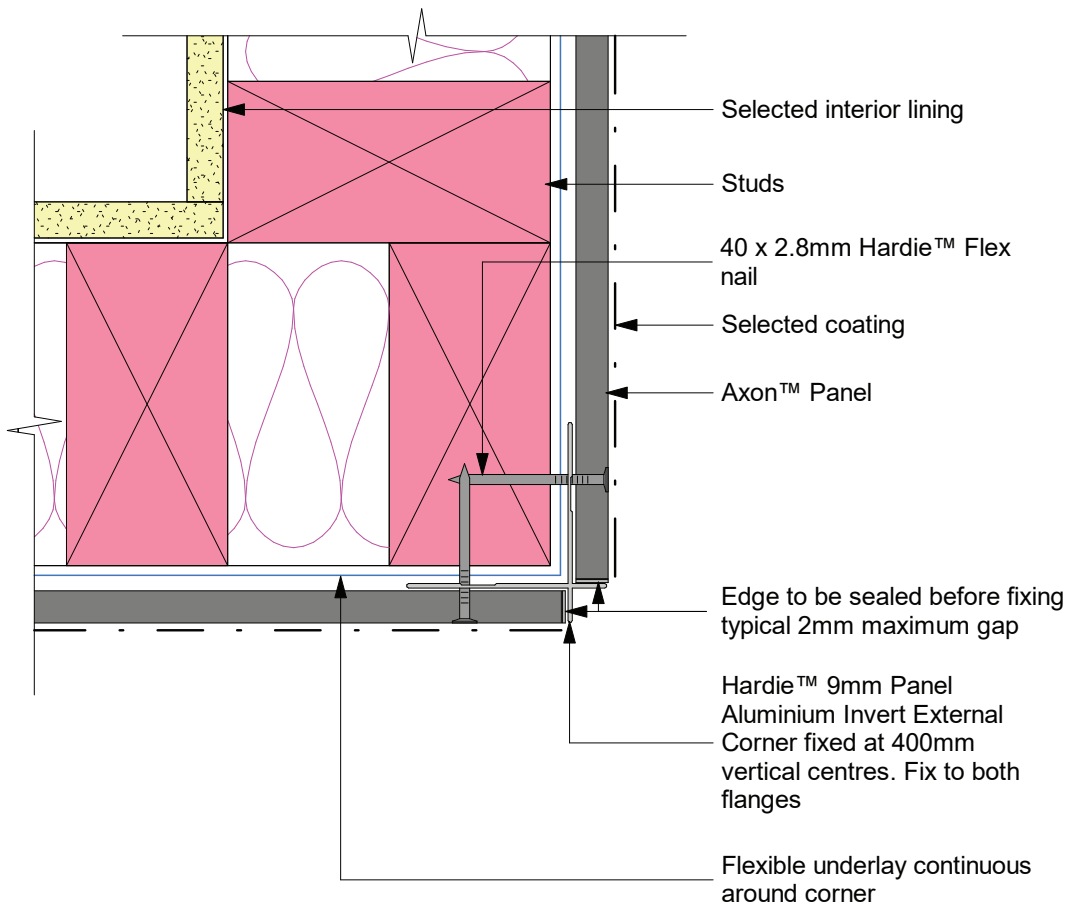

Figure 8: External corner radius detail



Note:
• Refer to Figure 12 for jointing with 'h' mould.

Figure 9: External corner invert detail



Note:

- Refer to Figure 12 for jointing with 'h' mould.

Figure 10: Hardie™ Axent™ Trim at joint

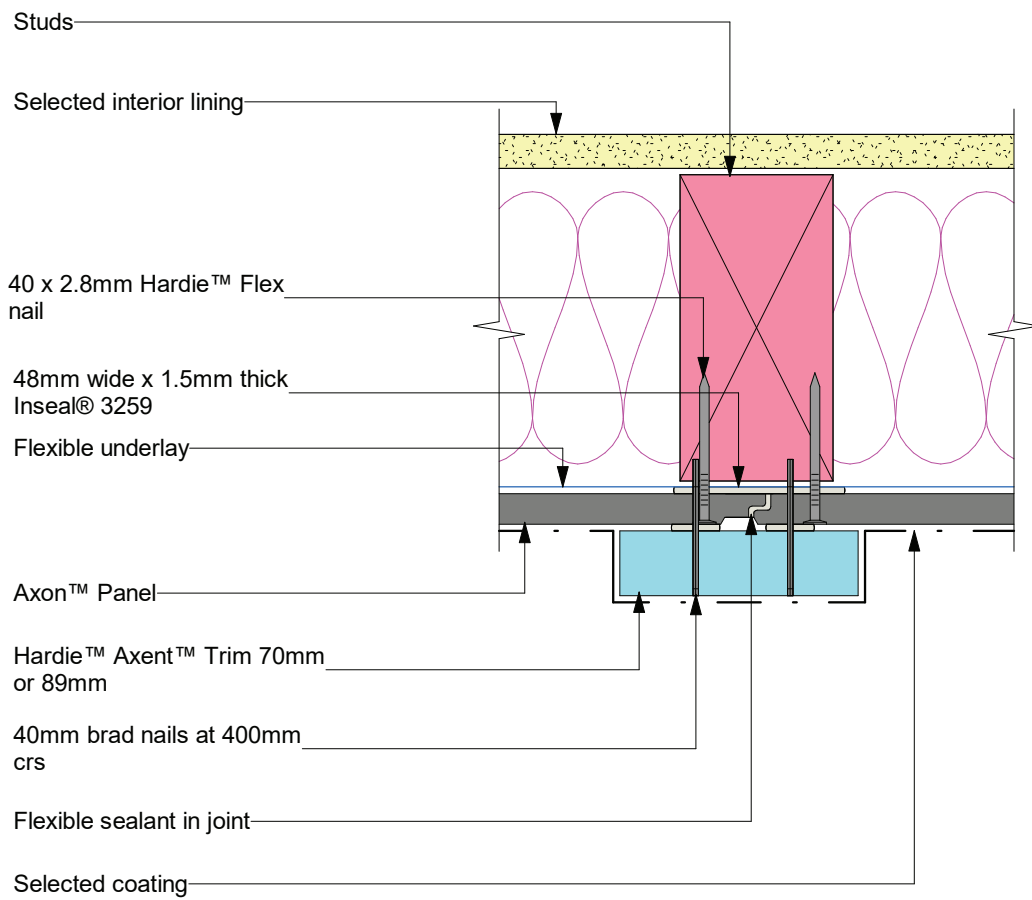

Note: Notes:

- Ensure that a continuous 6mm bead of adhesive sealant is applied between Hardie™ Axent™ Trim and Axon™ Panel.
- Ensure that the required edge distance is maintained when fixing.
- Seal cut edges with a primer compatible with final coatings.

Figure 11: Hardie™ Axent™ Trim 70 or 89mm intermediate framing

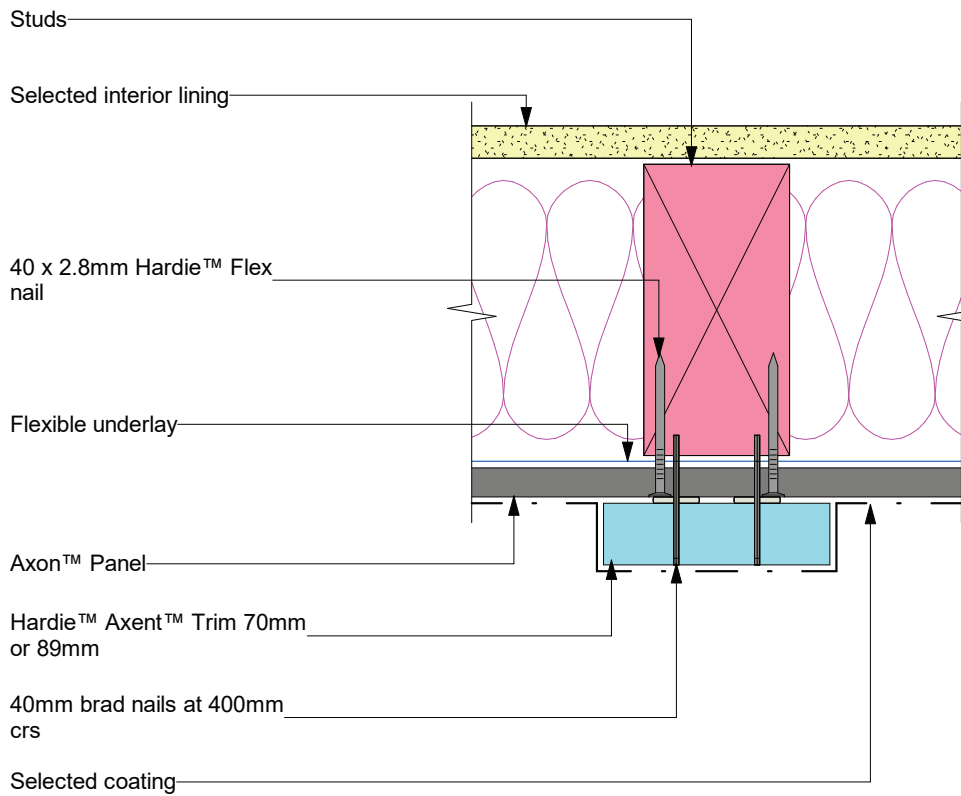

Note: Notes:

- * Ensure that a continuous 6mm bead of adhesive sealant is applied between Hardie™ Axent™ Trim and Axon™ Panel.
- * Ensure that the required edge distance is maintained when fixing.
- * Seal cut edges with a primer compatible with final coatings.

Figure 12: Hardie™ Axent™ Trim 45mm intermediate framing

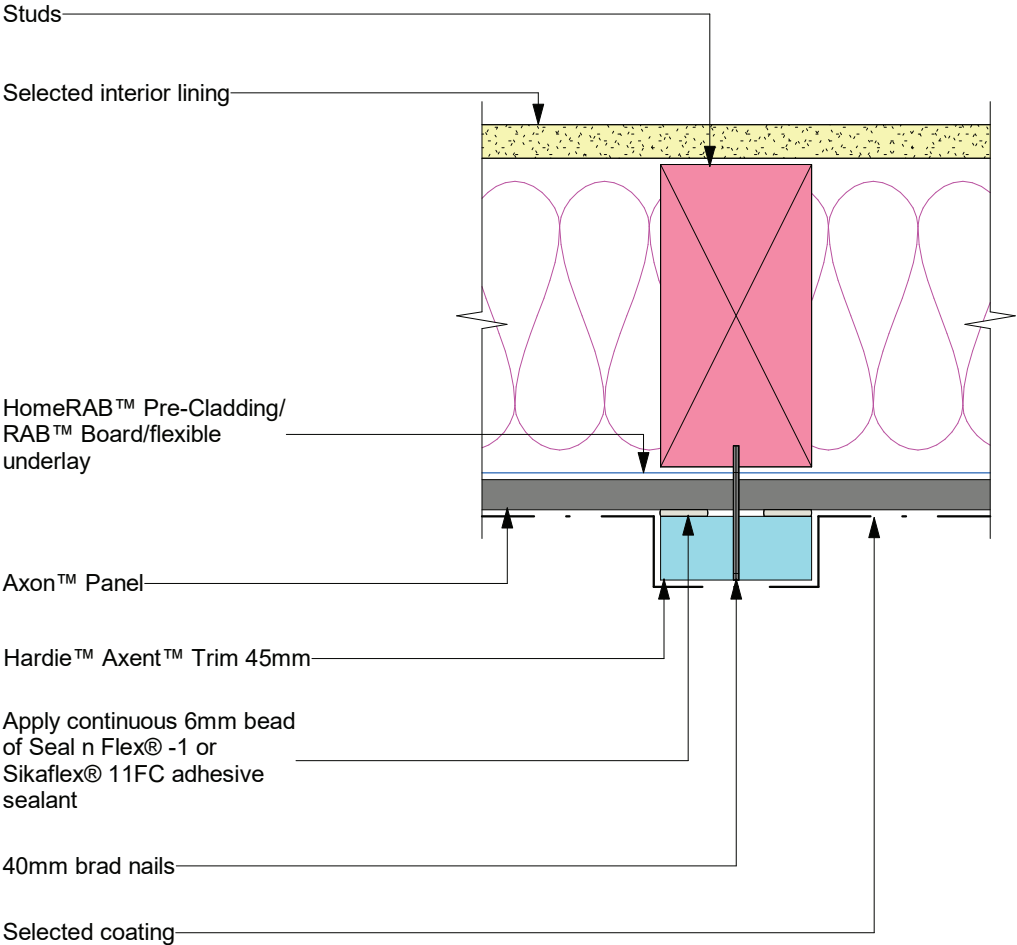

Note:
 * Ensure that the required edge distance is maintained when fixing.
 * Seal cut edges with a primer compatible with final coatings.

Figure 13: Hardie™ Axent™ Trim fixing

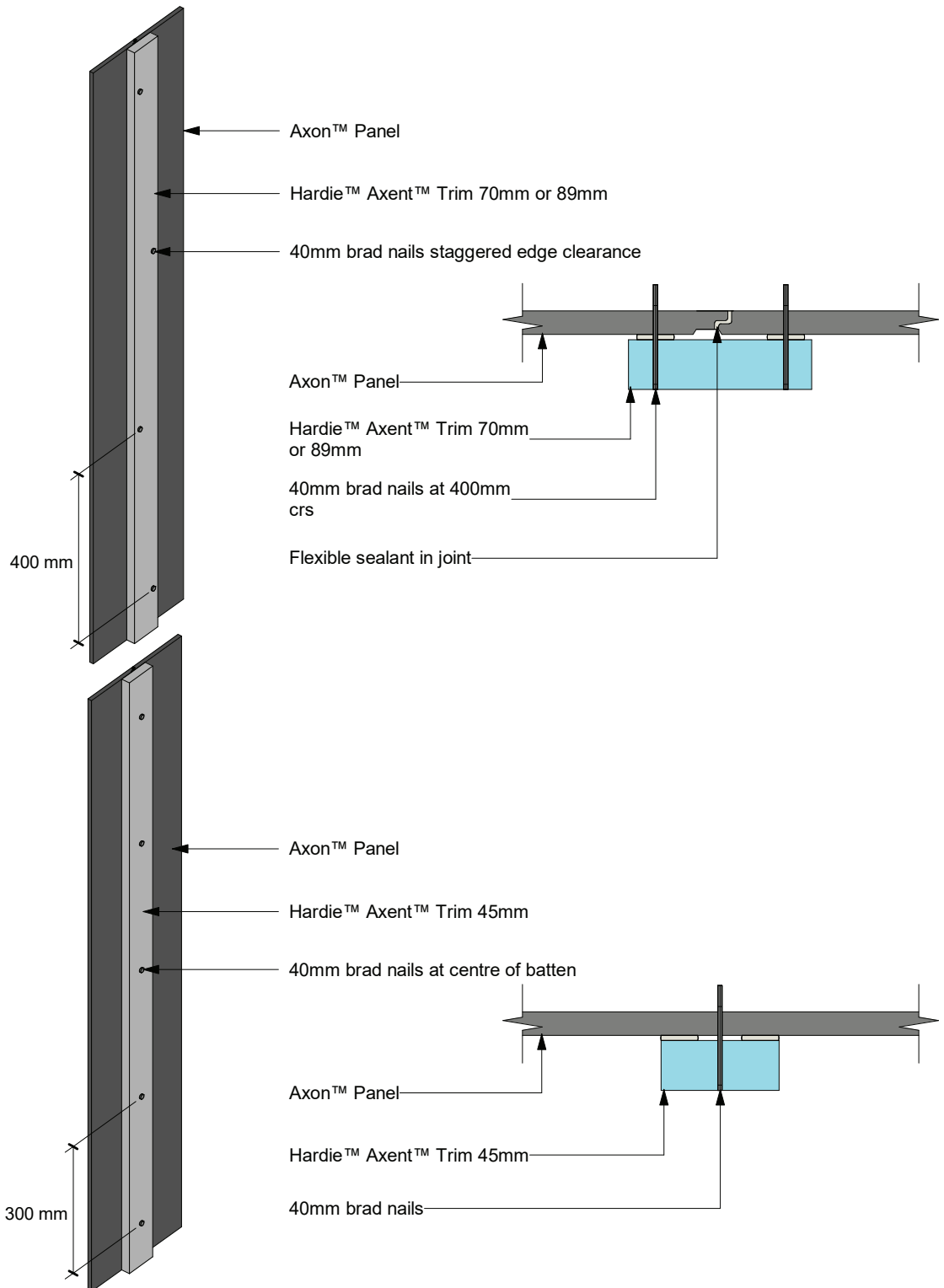

Figure 14: Hardie™ Axent™ Trim at internal corner

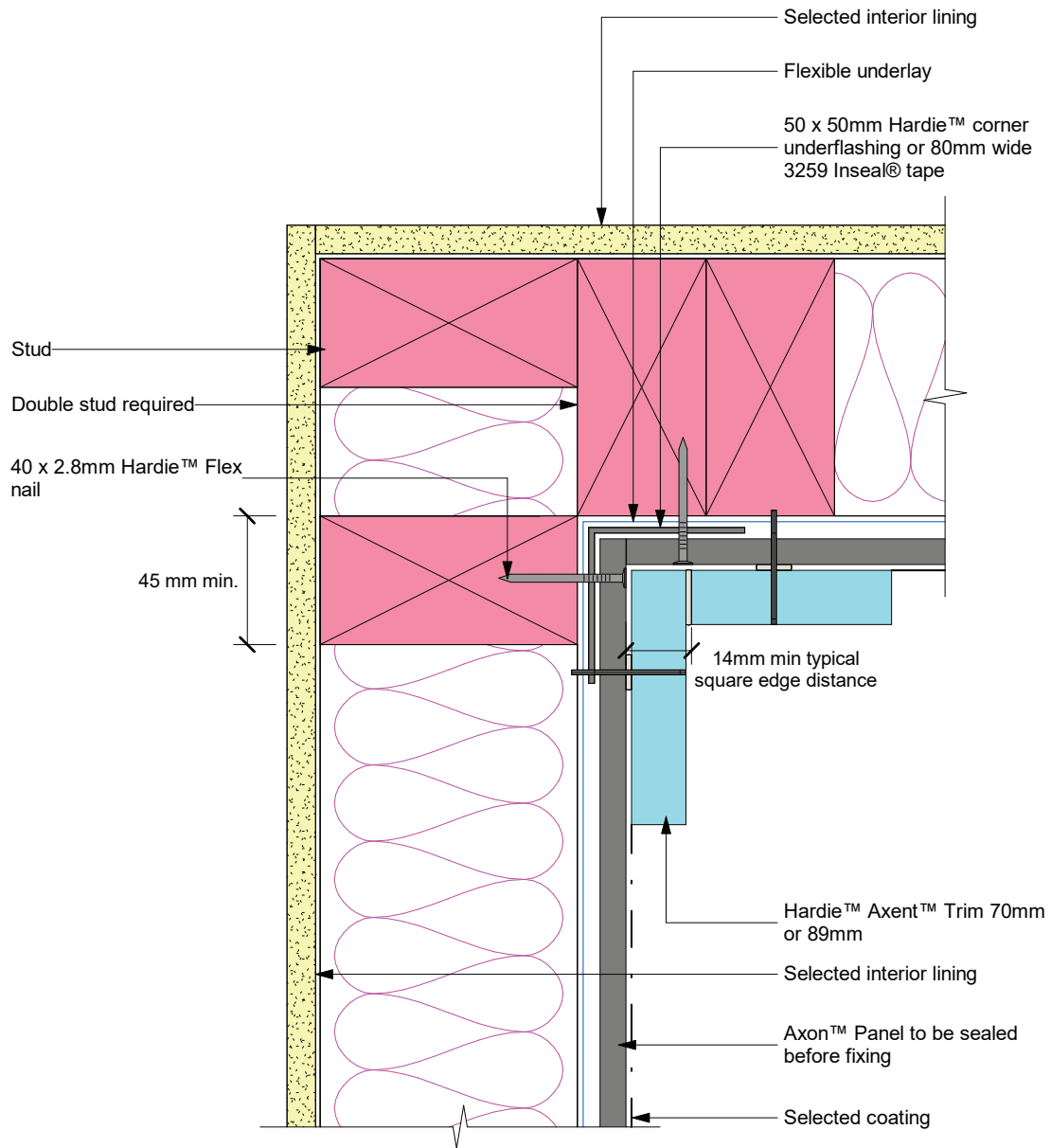
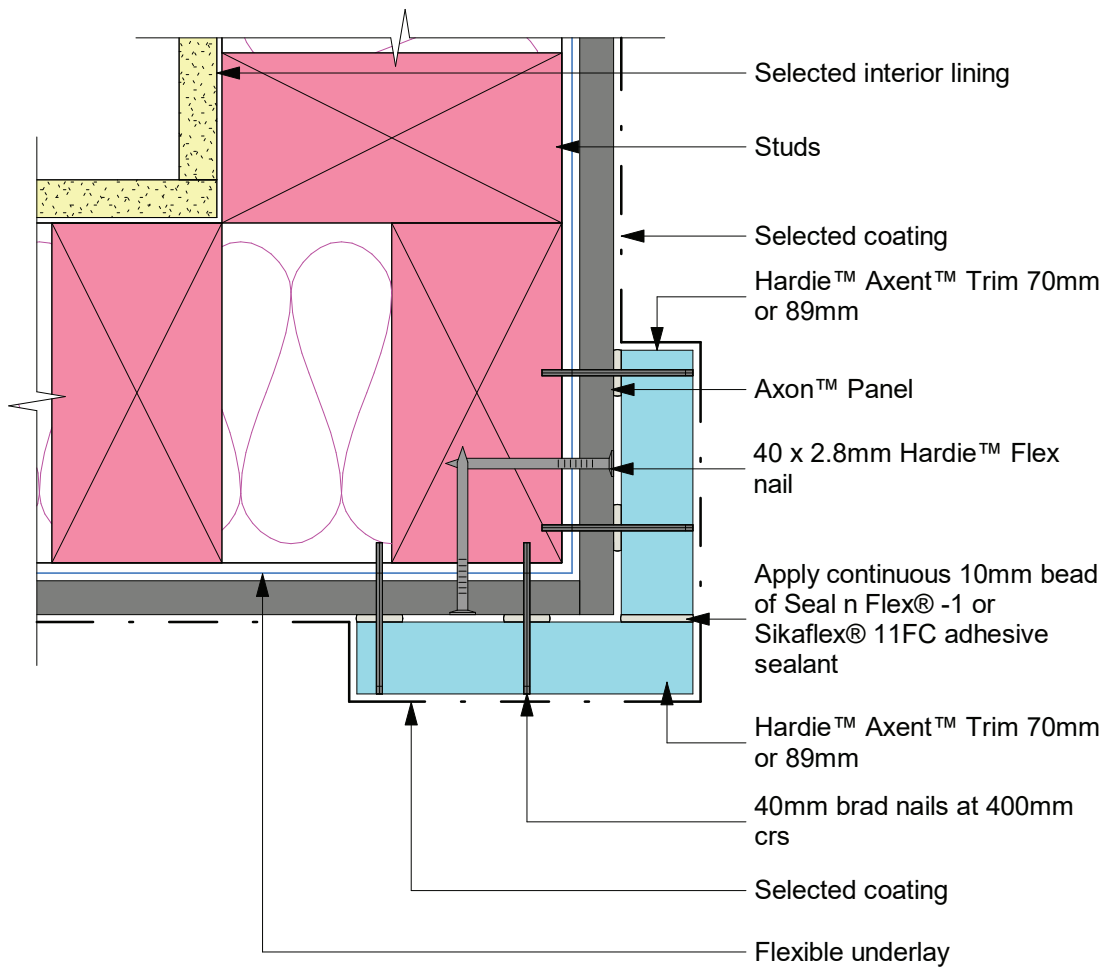

Figure 15: Hardie™ Axent™ Trim at external corner



Note:

- Refer to Figure 12 for jointing with 'h' mould.

Figure 16: Soffit detail

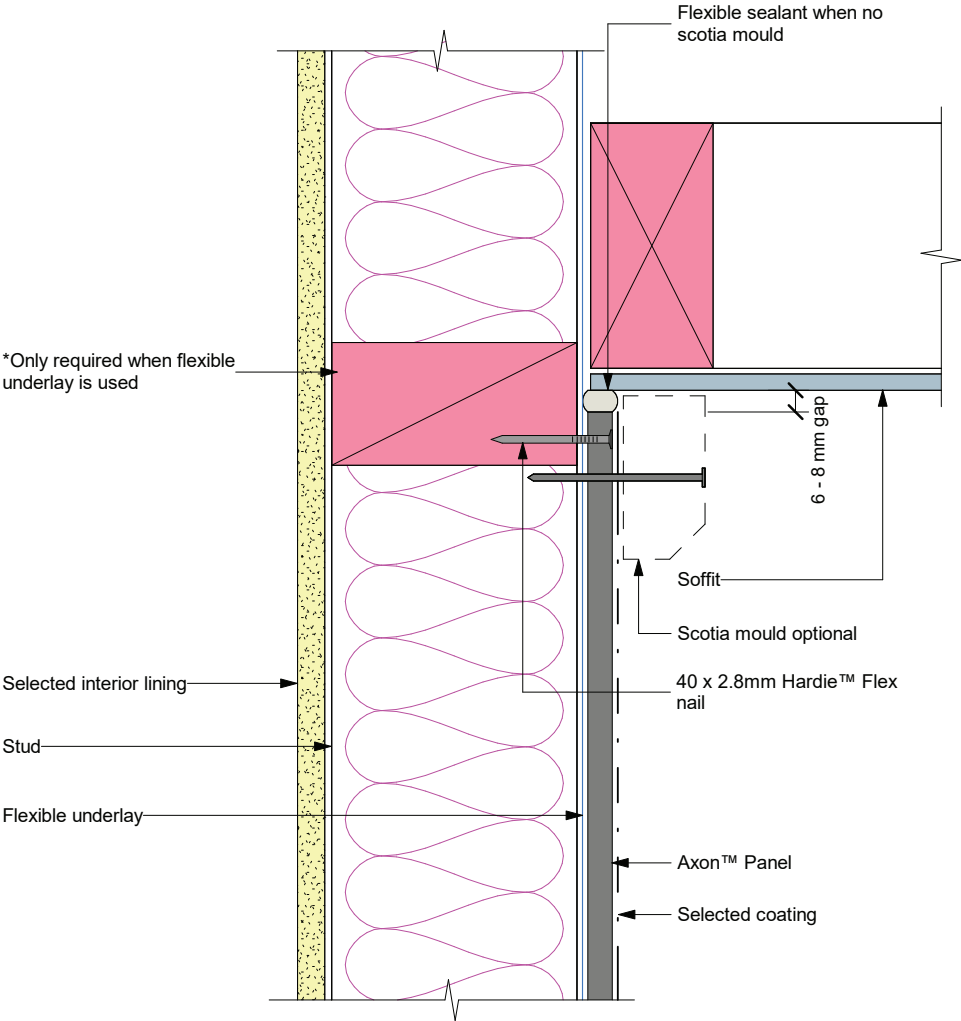

Note: Site cut edges to be primed

Figure 17: Window head

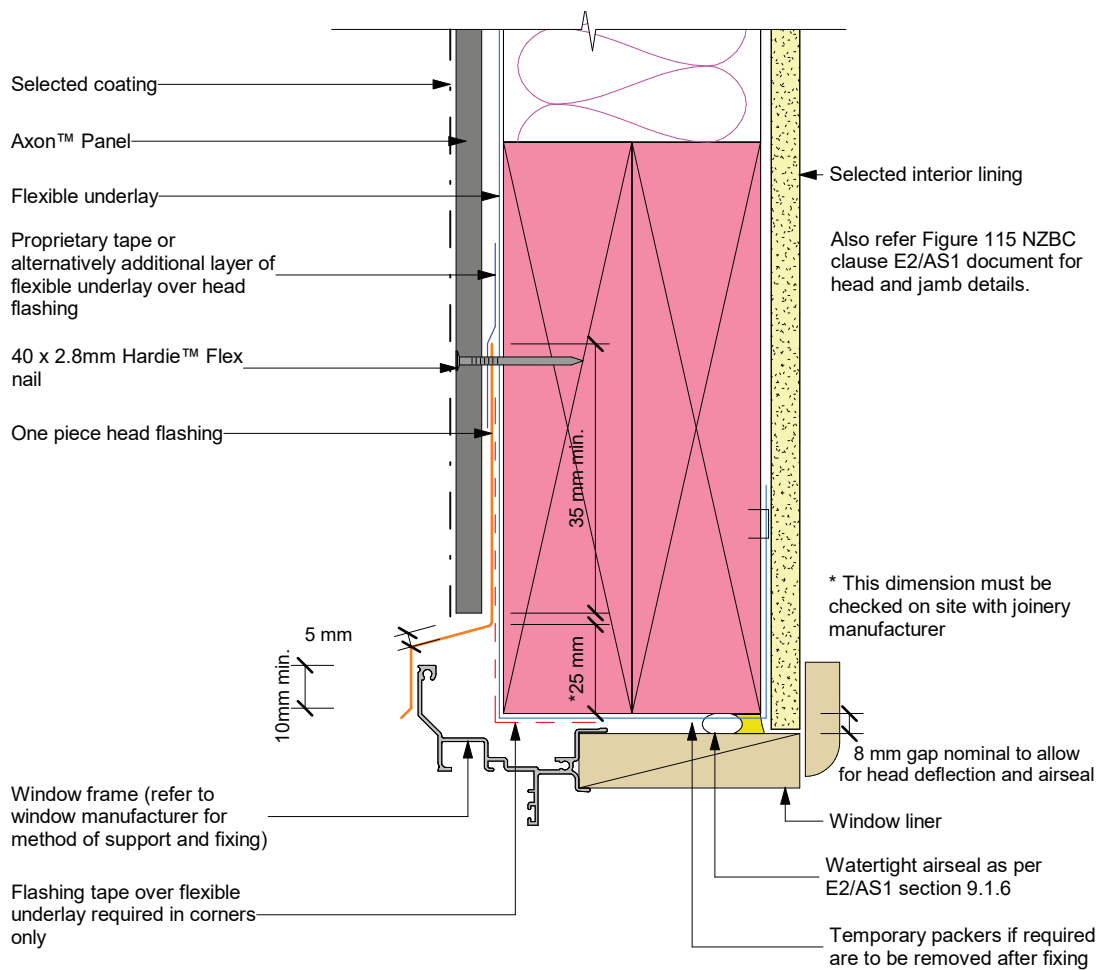
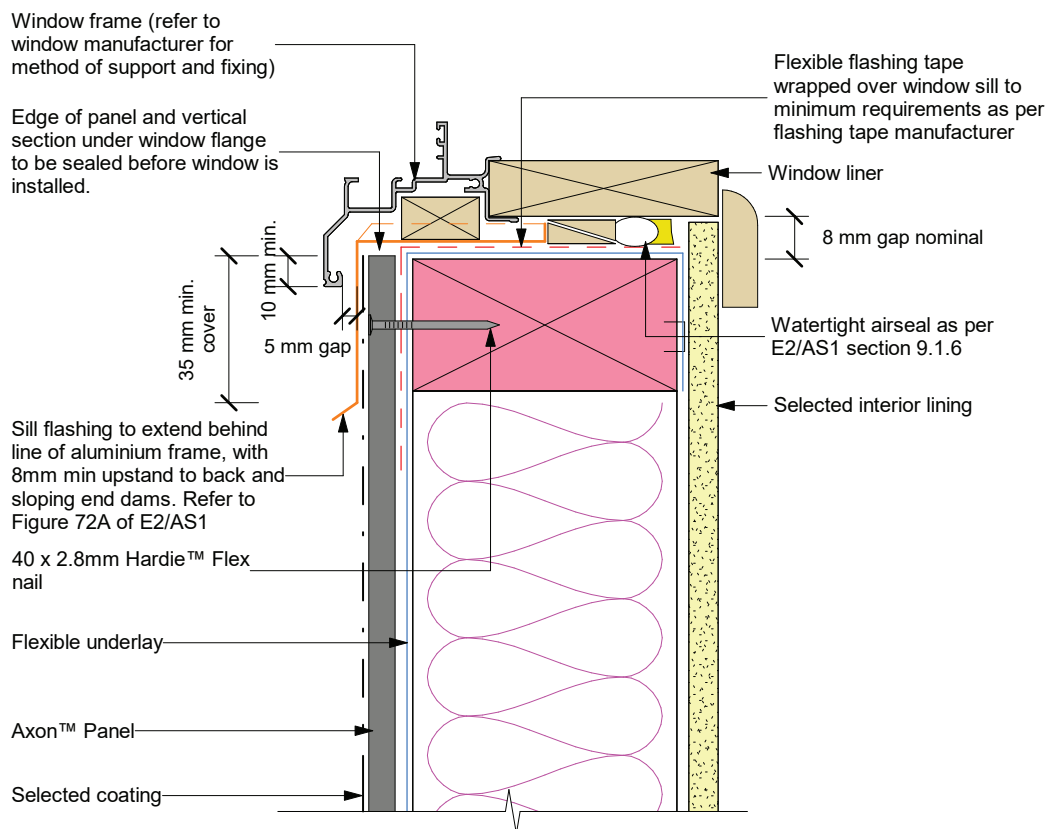

Figure 18: Section at sill



General notes for materials selection

- * Flashing materials must be selected based on environmental exposure, refer to the NZS 3604 and Table 20 of the NZBC E2/AS1.
- * Flexible underlay must comply with acceptable solution E2/AS.
- * Flashing tape must have proven compatibility with the selected flexible underlay and other materials with which it comes into contact.

Refer to the manufacturer or supplier for technical information for these materials.

Figure 19: Window jamb

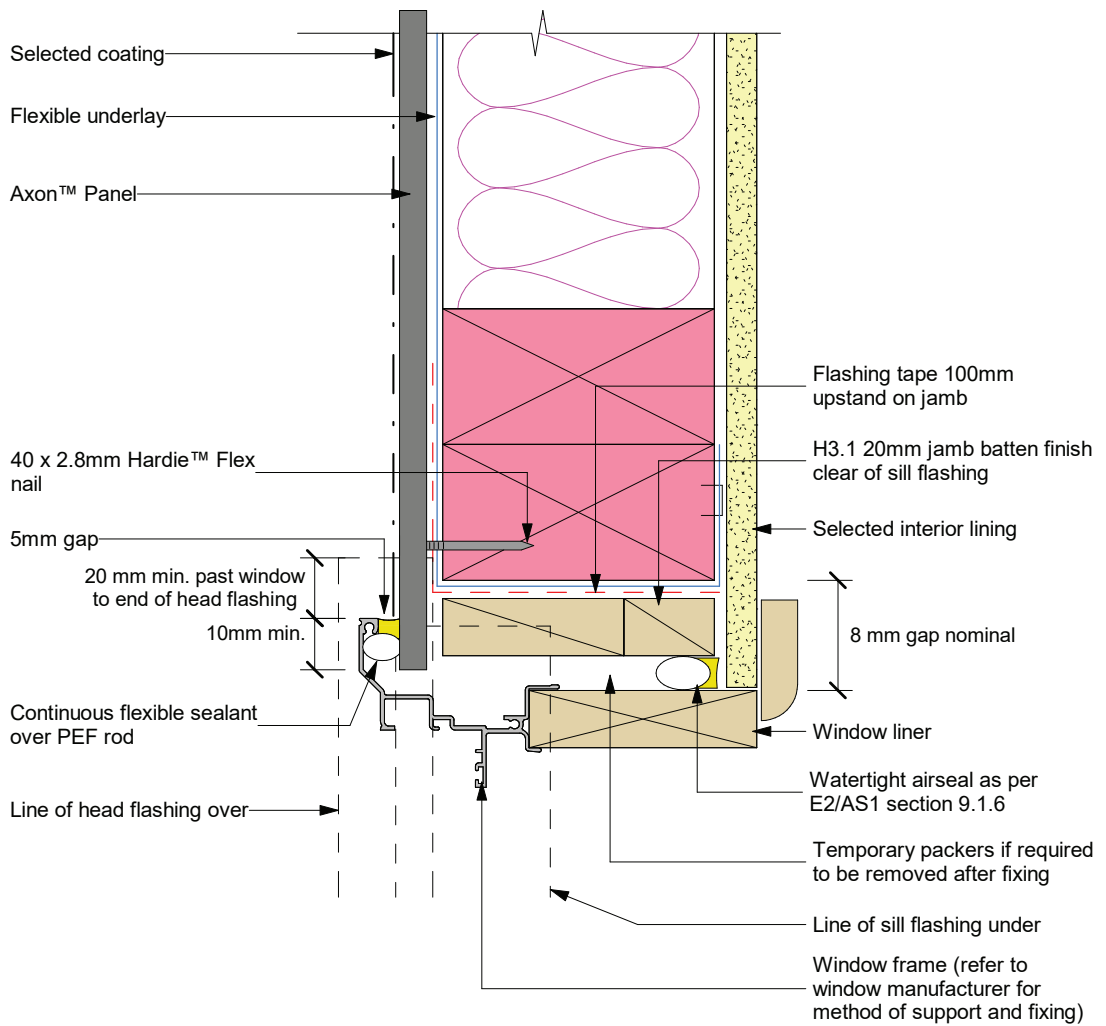
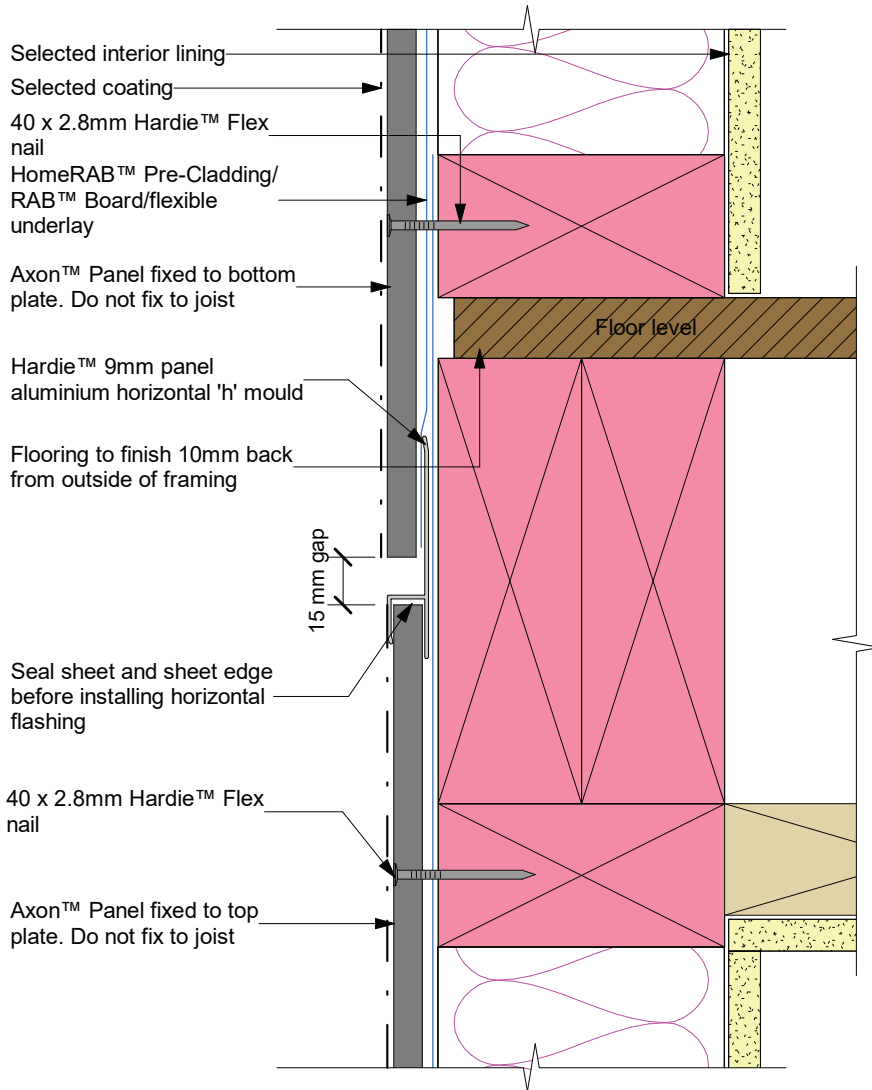
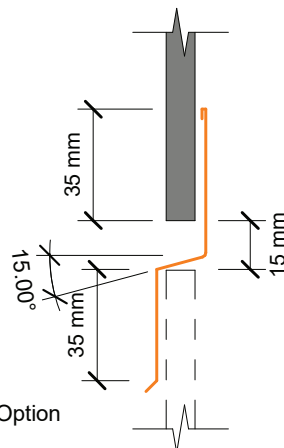

Figure 20: Horizontal joint detail



Note: When 50 year durability is required refer Table 20 of NZBC E2/AS1 document.



Alternative Flashing Option

Figure 21: Aluminium 'H' mould joiner

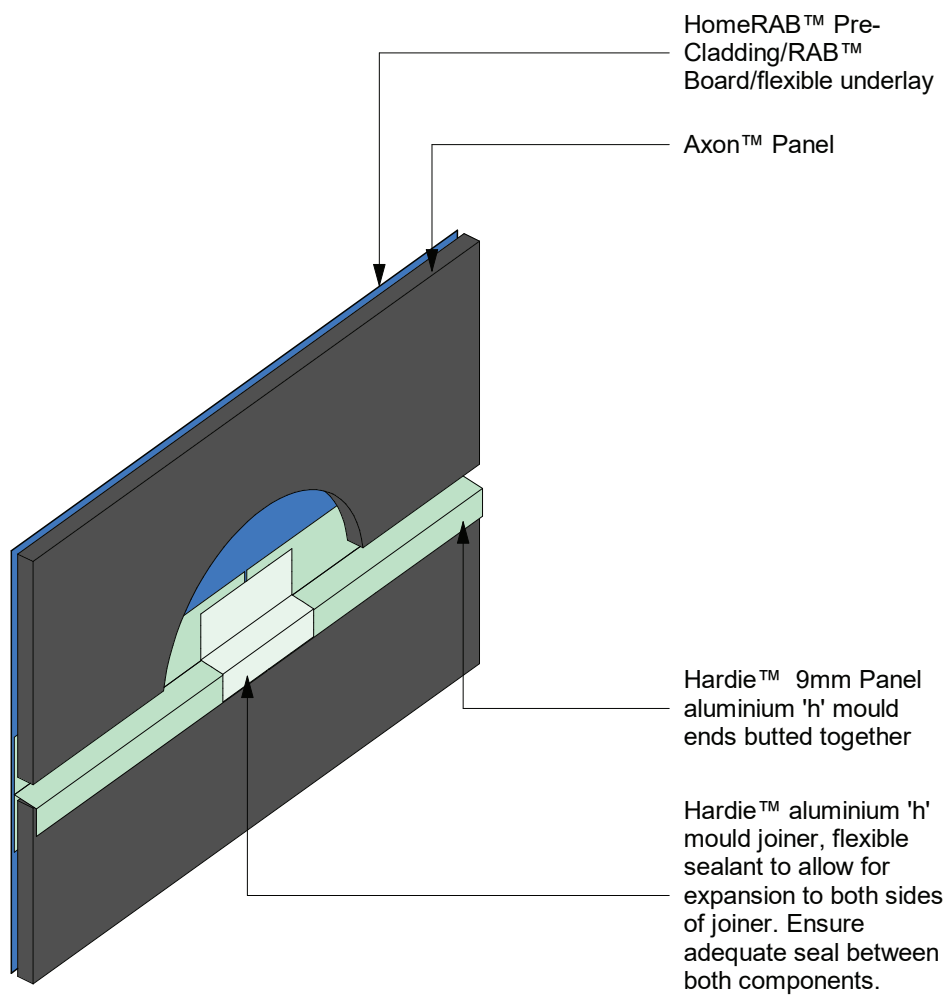
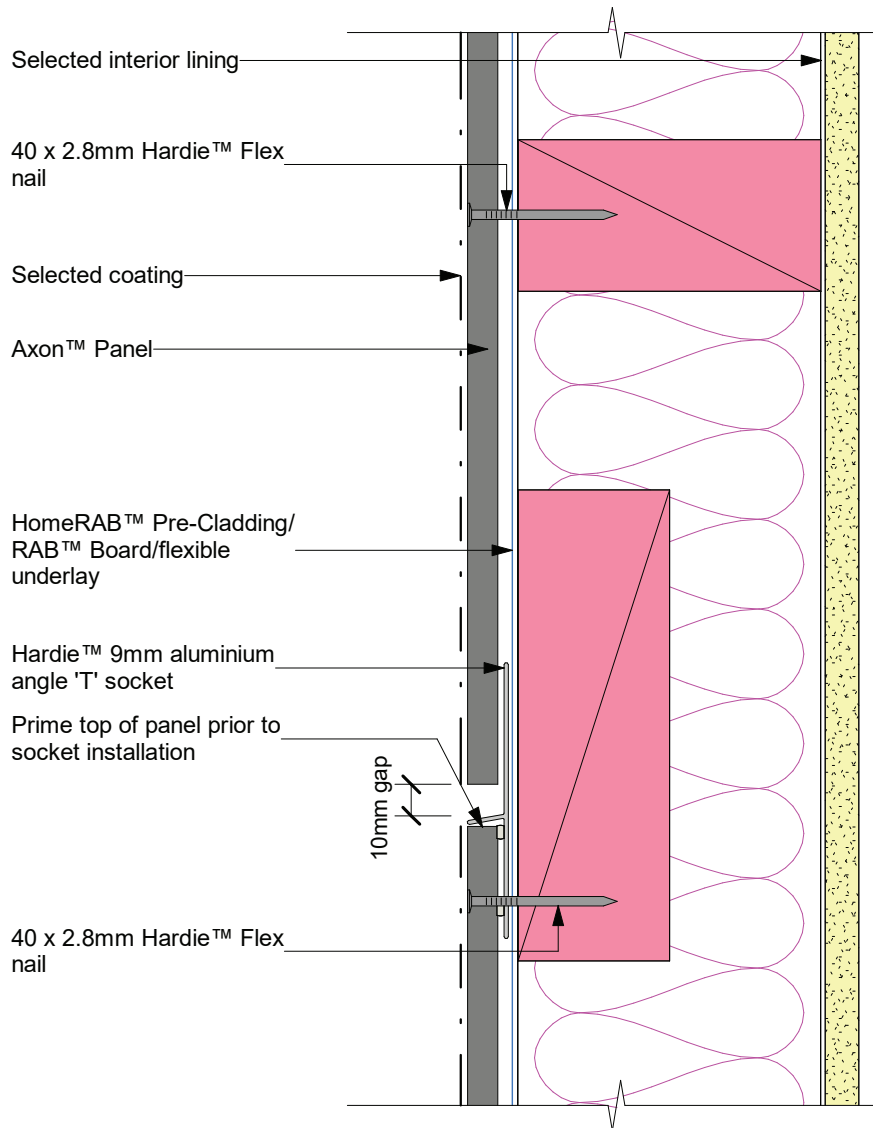

Figure 22: Horizontal joint detail with 'T' socket



Notes:

- Hardie™ 9mm aluminium angle 't' socket, take care to ensure continuous seal is formed between panel and the angle 't' socket
- Hardie™ angle 'T' horizontal jointer will be required over the butt joint of the Hardie™ 9mm aluminium angle 't' socket
- Site cut edges to be primed

Figure 23: Angle 'T' horizontal jointer

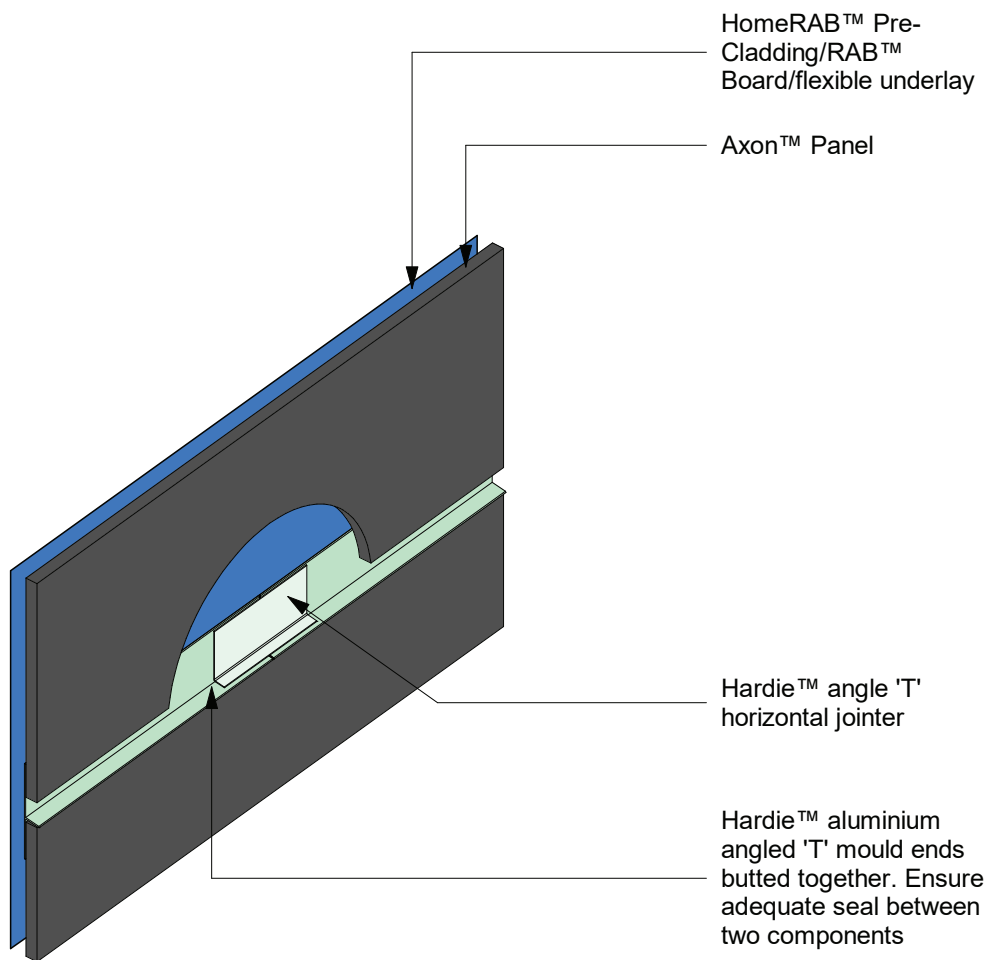

Figure 24: Corner at 'H' mould joint detail

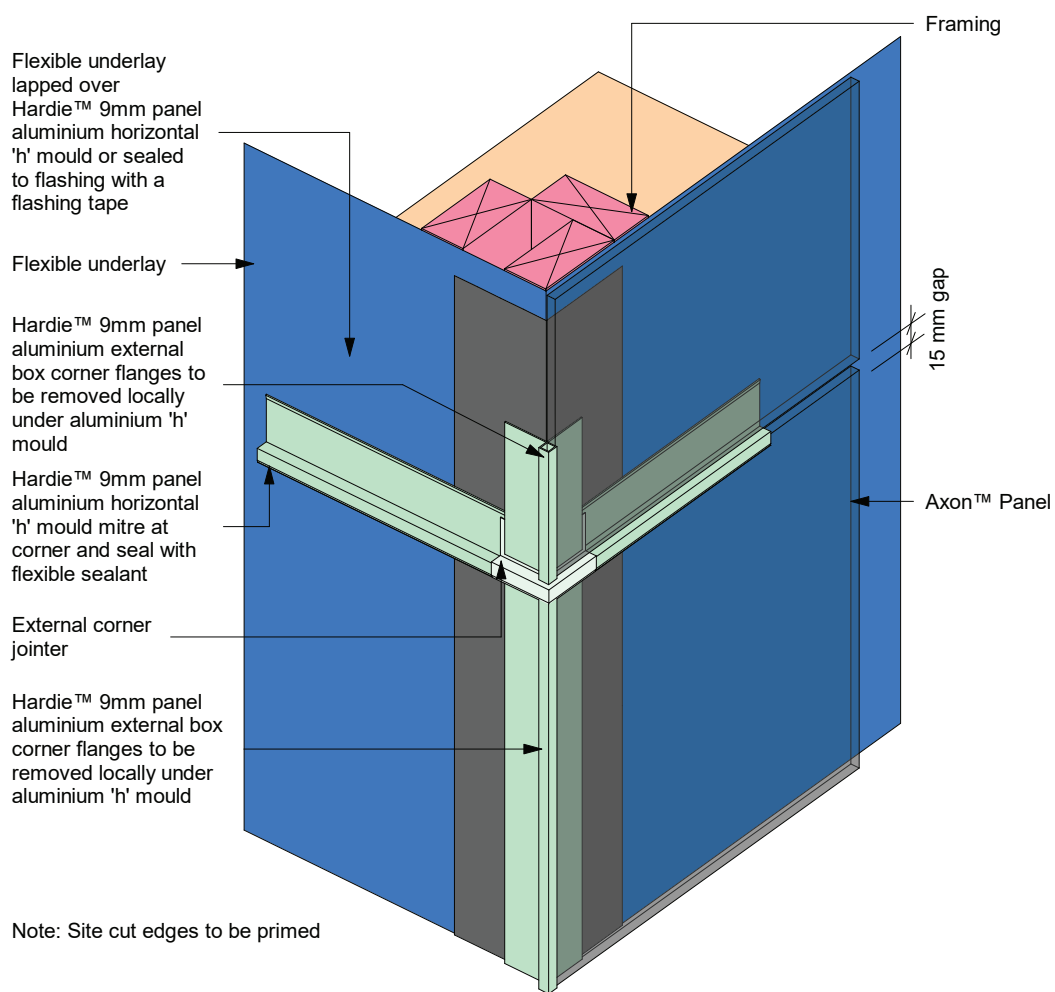
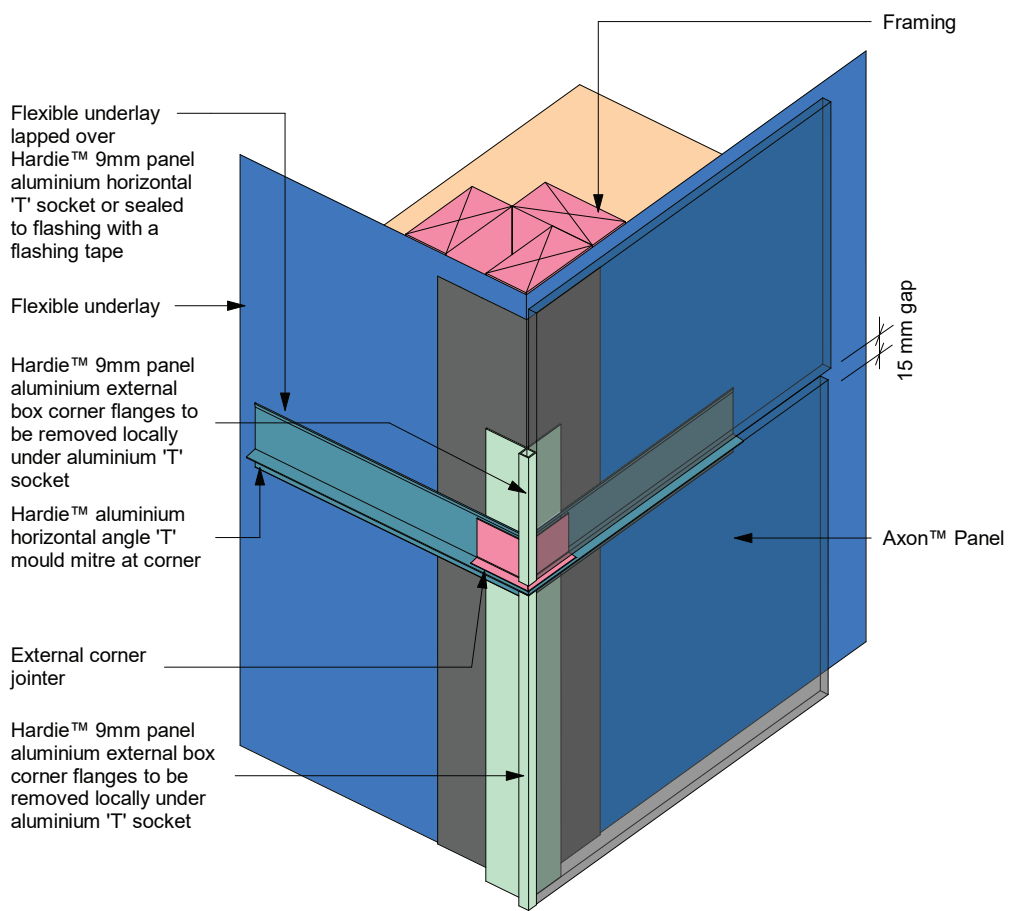

Figure 25: Corner at 'T' socket joint detail



Note: Site cut edges to be primed

Figure 26: Joining moulding

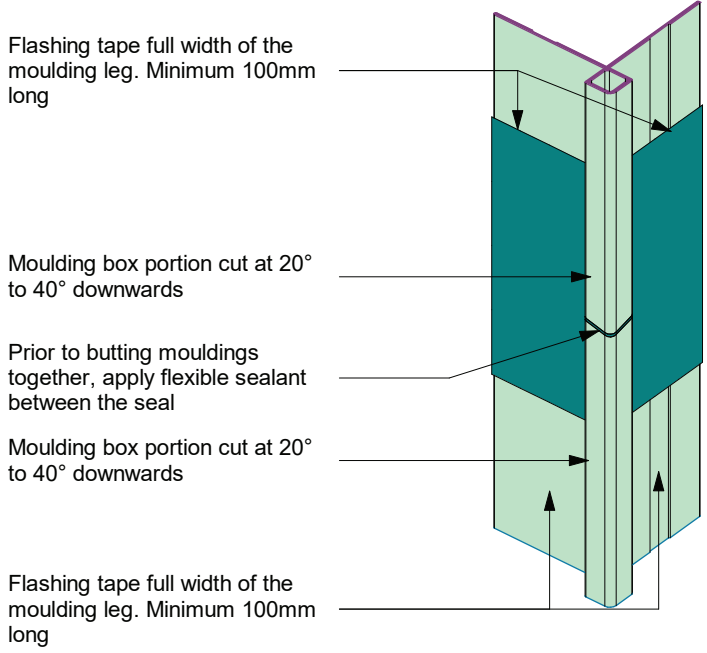
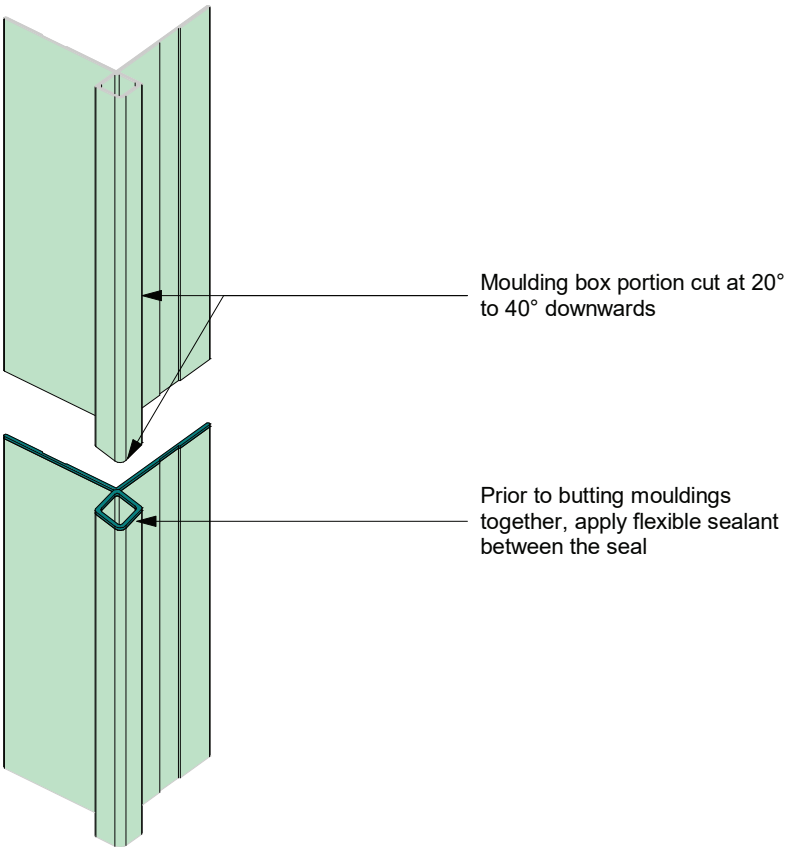
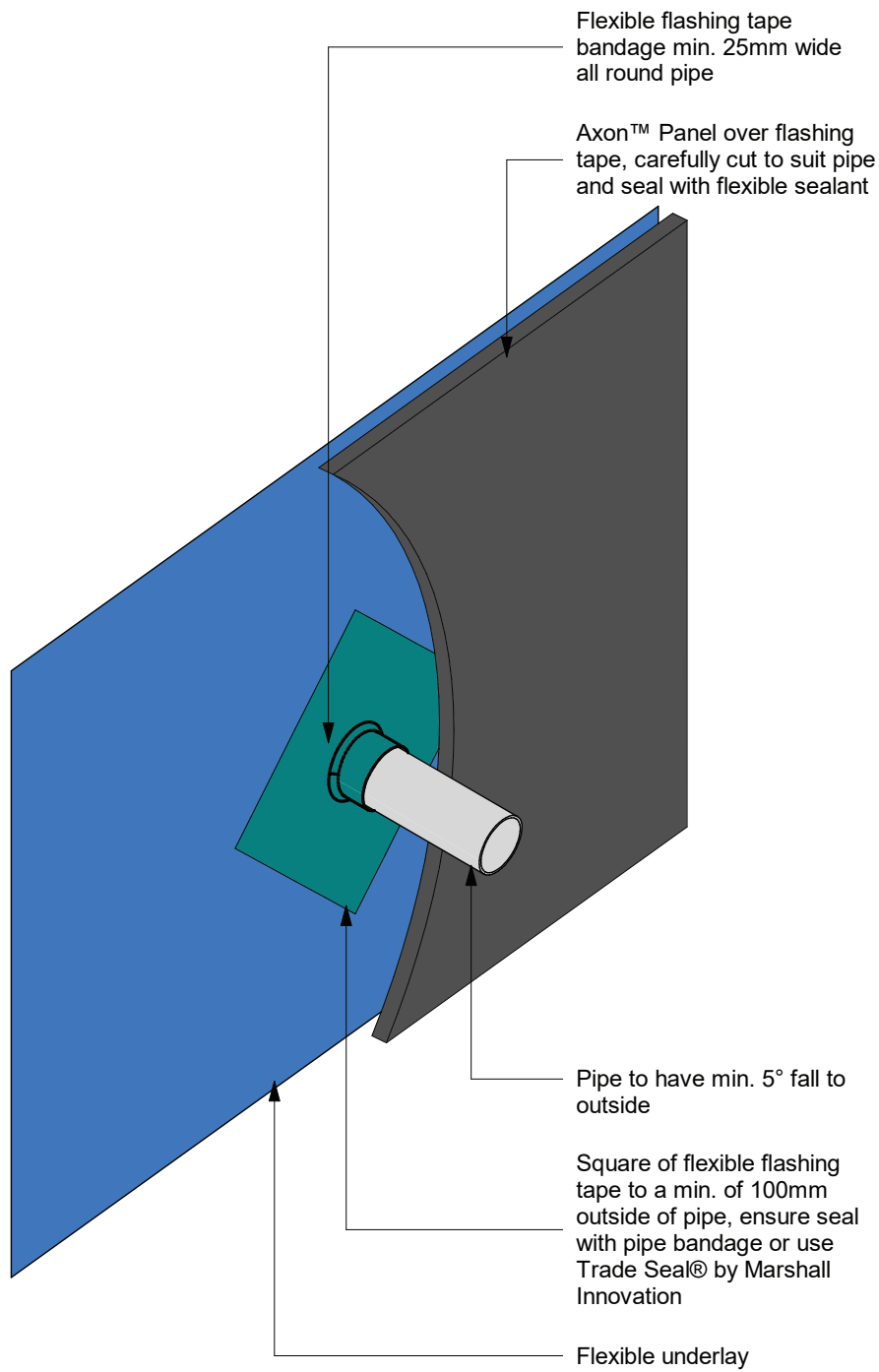
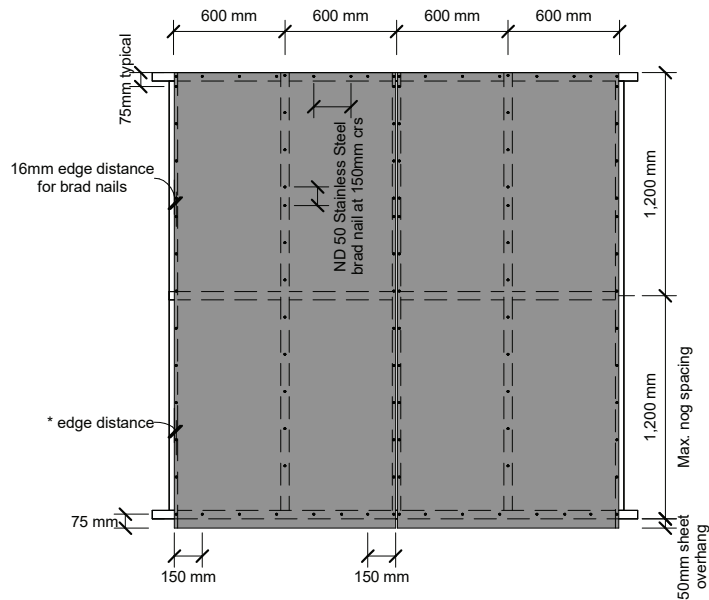

Figure 27: Cavity pipe penetration



Note: Site cut edges to be primed

Figure 28: Direct fixed typical panel brad nail fixing setout



Note: When studs spaced at 400mm centres using Axon™ Panel 400, the nail fixings to intermediate studs to be offset 5mm from the groove in Panel.

Figure 29: Shiplap joint - brad nail

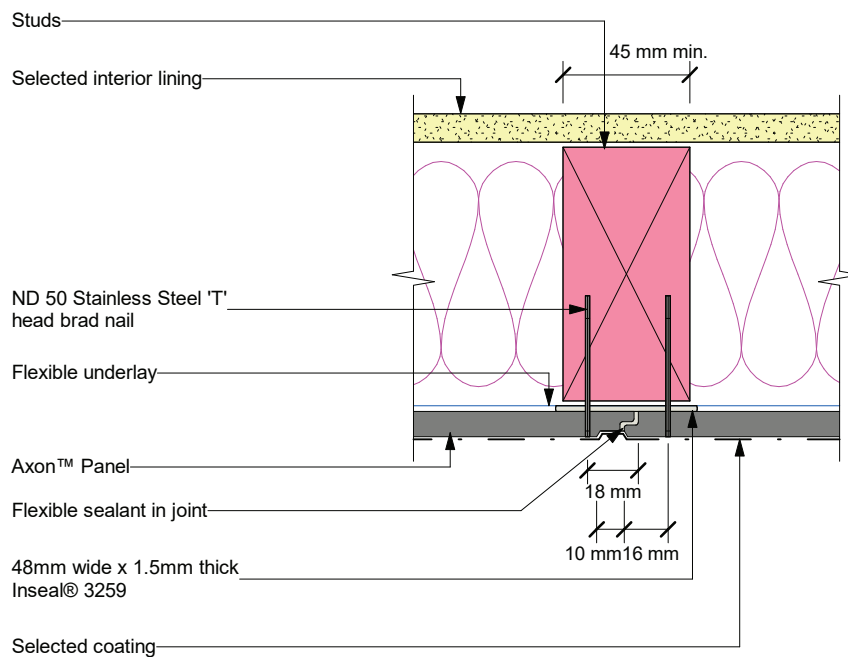

Product Warranty

James Hardie New Zealand Limited (“James Hardie”) warrants for a period of 15 years from the date of purchase that the Axon™ Panel (the “Product”), will be free from defects due to defective factory workmanship or materials and, subject to compliance with the conditions below, will be resistant to cracking, rotting, fire and damage from termite attacks to the extent set out in James Hardie’s relevant published literature current at the time of installation. James Hardie warrants for a period of 15 years from the date of purchase that the accessories supplied by James Hardie will be free from defects due to defective factory workmanship or materials.

Nothing in this document shall exclude or modify any legal rights a customer may have under the Consumer Guarantees Act or otherwise which cannot be excluded or modified at law.

CONDITIONS OF WARRANTY:

The warranty is strictly subject to the following conditions:

- a) James Hardie will not be liable for breach of warranty unless the claimant provides proof of purchase and makes a written claim either within 30 days after the defect would have become reasonably apparent or, if the defect was reasonably apparent prior to installation, then the claim must be made prior to installation.
- b) This warranty is not transferable.
- c) The Product must be installed and maintained strictly in accordance with the relevant James Hardie literature current at the time of installation and must be installed in conjunction with the components or products specified in the literature. Further, all other products, including coating and jointing systems, applied to or used in conjunction with the Product must be applied or installed and maintained strictly in accordance with the relevant manufacturer’s instructions and good trade practice.
- d) The project must be designed and constructed in strict compliance with all relevant provisions of the current New Zealand Building Code (“NZBC”), regulations and standards.
- e) The claimant’s sole remedy for breach of warranty is (at James Hardie’s option) that James Hardie will either supply replacement product, rectify the affected product or pay for the cost of the replacement or rectification of the affected product.
- f) James Hardie will not be liable for any losses or damages (whether direct or indirect) including property damage or personal injury, consequential loss, economic loss or loss of profits, arising in contract or negligence or howsoever arising. Without limiting the foregoing James Hardie will not be liable for any claims, damages or defects arising from or in any way attributable to poor workmanship, poor design or detailing, settlement or structural movement and/or movement of materials to which the Product is attached, incorrect design of the structure, acts of God including but not limited to earthquakes, cyclones, floods or other severe weather conditions or unusual climatic conditions, efflorescence or performance of paint/coatings applied to the Product, normal wear and tear, growth of mould, mildew, fungi, bacteria, or any organism on any Product surface or Product (whether on the exposed or unexposed surfaces).
- g) All warranties, conditions, liabilities and obligations other than those specified in this warranty are excluded to the fullest extent allowed by law.
- h) If meeting a claim under this warranty involves re-coating of Products, there may be slight colour differences between the original and replacement Products due to the effects of weathering and variations in materials over time.

Disclaimer: The recommendations in James Hardie’s literature are based on good building practice, but are not an exhaustive statement of all relevant information and are subject to conditions (c), (d), (f) and (g) above. James Hardie has tested/assessed the performance of the Axon™ Panel when installed in accordance with the relevant Axon™ Panel technical specification, in accordance with the standards and verification methods required by the NZBC and those test results demonstrate the product complies with the performance criteria established by the NZBC. However, as the successful performance of the relevant system depends on numerous factors outside the control of James Hardie (e.g. quality of workmanship and design) James Hardie shall not be liable for the recommendations made in its literature and the performance of the relevant system, including its suitability for any purpose or ability to satisfy the relevant provisions of the NZBC, regulations and standards, as it is the responsibility of the building designer to ensure that the details and recommendations provided in the relevant James Hardie installation manual are suitable for the intended project and that specific design is conducted where appropriate.

© 2023. James Hardie New Zealand Limited. TM and ® denotes a Trademark or Registered Mark owned by James Hardie Technology Limited.

